

Pvm. Date	Revisio Revision	Muutoksen ja korjauksen selitys Amendment and correction explanation	Muuttanut Amended

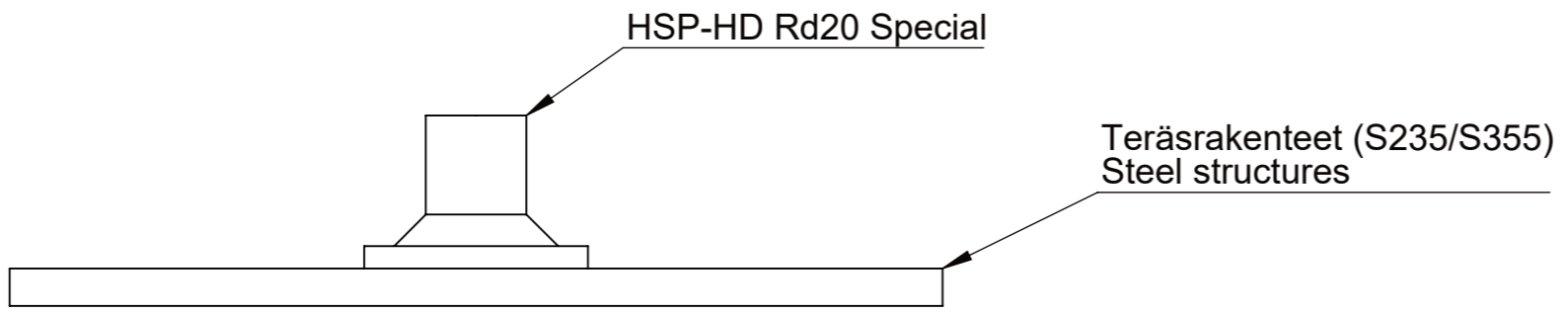

Toteusluokka EXC3 (EN 1090-2)
 EN ISO 3834-2
 Hitsauspätevyys EN 287-1
 Hyväksymiskriteeri EN ISO 5817 hitsiluokka B
 NDT EN1090-2 taulukko 24

Execution class EXC3 (EN 1090-2)
 EN ISO 3834-2
 Qualification EN 287-1
 Acceptance EN ISO 5817 welding class B
 NDT EN1090-2 table 24

Hissin nostopisteen nimelliskuorma 20kN
 Lifting point nominal load 20kN

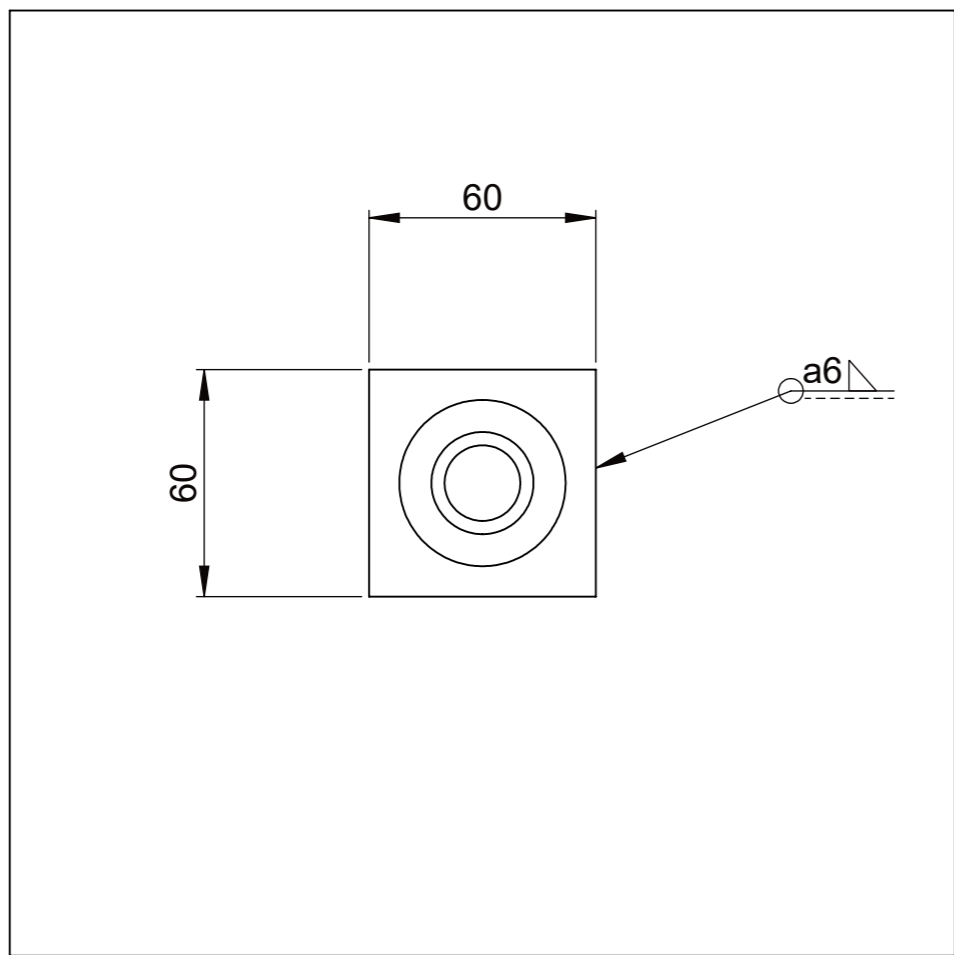

Merkitemättömät valmistustoleranssit Dimensional tolerances without tolerance indication		Hitsaus: A SFS 3393 Welding:		Polttoleikkaus: II AH SFS 4072 Oxygen cutting:		Leikkaus ja taivutus: SFS 4012 Cutting and bending		Hitsausluokka: Welding class: SFS-EN 25817 WC	
Lastuaminen: SFS-EN 22768-1 Keski Machining: Medium		Kokonaispaino Total weight		5.2 kg		Position No. Position No.		01	
Suunnitelut Designed		Projekti No. Project No.		10274		Suhteen Related To		HSP-HD Rd20 Special	
Tarkastanut Checked		SEMTU OY Hitsausohje hissinospisteelle Rd20 Welding instructions for lift construction attachment point							
Hyväksynyt Approved									
Päiv. Date		Nimi Name		Piirustus No. Drawing No.		Muutos Revision		Koko Size	
				10274_01_001				A3	
								Suhde Scale 1:2	

