

HALFEN DEMU

INST_DEMU-FIX 12/22

EN Fixing Anchors

DE Hülsenanker

FR Douilles de fixations

ES Casquillos de fijación

NL Bevestigingsankers

PL Kotwy tulejowe



Assembly Instructions • Montageanleitung • Notice d'utilisation • Instrucciones de montaje
Montagehandleiding • Instrukcja montażu

Anchor types

This assembly instruction is for the following types of HALFEN DEMU Fixing anchors:

T-FIXX® (GV, A4)



Bar anchor

types 4010 (GV, FV), 4030 (GV, FV), 3016 (GV), 3010 (A4-80), 1980-S (GV), 1988-S (GV), 1554 (GV, FV, A4-80), 1558 (GV, FV, A4-80)

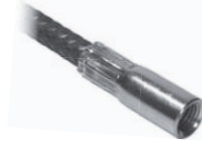

Bolt anchor

types 1988 (GV, FV, A4-50, A4-80), 1985 (GV), 1980-P (GV, FV, A4-80)



Socket anchor

types 995-GB (GV), 995 (A4), 995-G (GV, A4), 995-DG (GV), 1036-G (GV, A4), 1130 (GV), 1140 (GV, A4)



General notes on installation

In order to guarantee best possible bond between the fixing anchor and the concrete, make sure that the surface of the anchor is free from dirt, oil, etc.

The concrete has to be poured carefully; please avoid direct contact between the compacting device and the fixing anchor. Additional securing of the anchors by wire-tying is recommended.

The fixing anchors may be embedded flush or recessed in the concrete. It is strongly recommended to use washers to shim if anchors are recessed.

Shortly after striking the formwork the nailing plates should be removed.

The inside of the threaded socket must be dry and protected against ingress of water, dirt or oil until required for use i.e. for fixing components. Ensure the inside of the socket remains dry after final assembly.

The fixing component (bolt with standard metric thread) has to be selected according to the static engineer's specifications. Minimum / maximum screw-in length for bolts and maximum installation torque moment (T_{inst}) can be found on pages 6 - 7.

The fixing anchor must not be subjected to full load capacity until the concrete has reached its final strength.

Welding

All HALFEN DEMU-products shown in our Technical Product Information "DEMU FIX" are weldable. However, any welding, including tack welding, to HALFEN DEMU-products can negatively influence their mechanical properties. Welding can affect the performance of the product.

If welding in the application is unavoidable, take the following into account:

- a possible change in performance; a possible reduction in load capacity
- remove any coating layer before welding, and ensure welding fumes are safely extracted during welding
- use mandatory protective equipment
- the customer is responsible for making sure that applicable welding regulations are respected

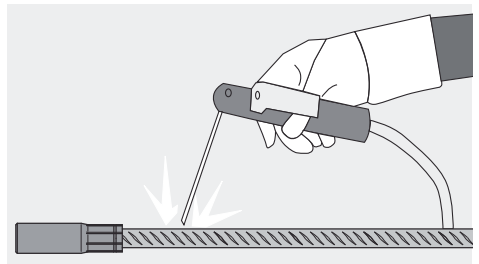

Leviat is not liable for any damage caused to or by HALFEN DEMU products that have been subsequently welded.

Assembly of accessories

Nailing plate

Type 2275 (h = 2 mm)



Type 2280 (h = 10 mm)



Fixing pin

Type 2250



Available thread sizes: M8 – M30

d_{nom}	M8*	M10	M12	M16	M20	M24	M30*
-----------	-----	-----	-----	-----	-----	-----	------

* only type 2280 available

Figure 1

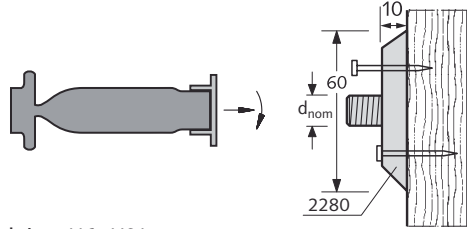

Available thread sizes: M6 – M24

d_{nom}	M6	M8	M10	M12	M16	M20	M24
\varnothing drilling hole [mm]	11	11	11	11	17	17	17

Figure 2

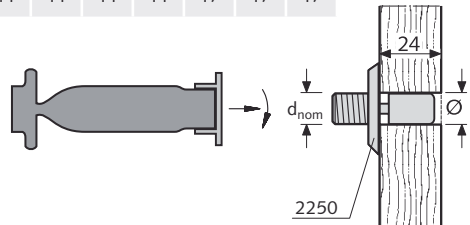

Sealing cap

Type 2244



Available thread sizes: M6 – M42

d_{nom}	M6	M8	M10	M12	M16	M20	M24	M30	M36	M42
-----------	----	----	-----	-----	-----	-----	-----	-----	-----	-----

Figure 3

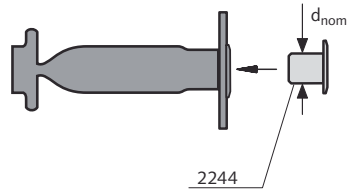

Thread adapter

Type 2600



Available thread sizes: M12 – M42

d_{nom}	M12	M16	M20	M24	M30	M36	M42
d_B fixing bolt	M6	M8	M8	M10	M10	M10	M12

Figure 4

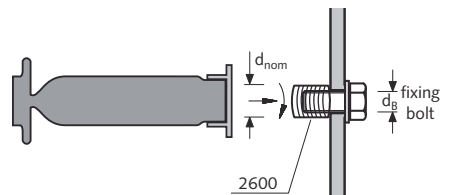

Assembly steps (shown: T-FIXX; fixing of other anchor types analogical)

Fixing to the formwork

Preparing for assembly

Screw-in and fixing of the bolt ①

Case A
with plastic nailing plate

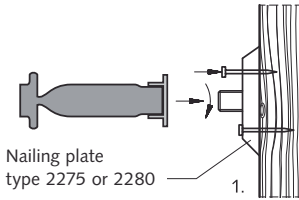

Assembly of nailing plate:
see page 3, figure 1

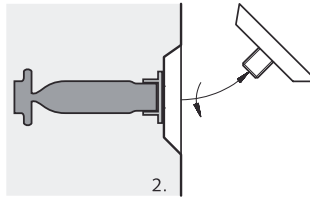

Remove formwork,
unscrew the nailing plate

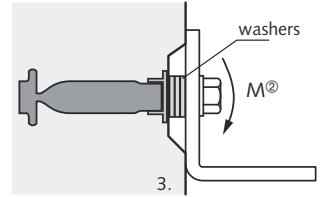

Case B
with plastic fixing pin

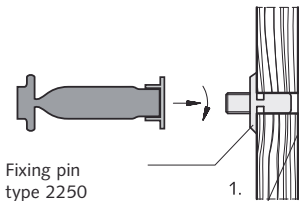

Drill hole in formwork:
see page 3, figure 2

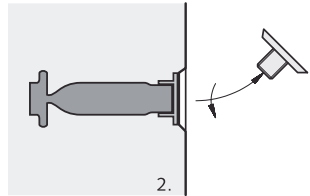

Remove formwork,
unscrew remainder of fixing pin

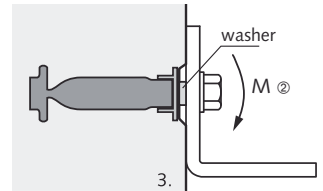

Case C
Fixing anchors with integrated nailing plate

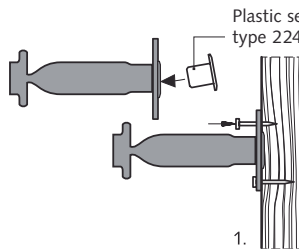

Fixing of sealing cap:
see page 3, figure 3

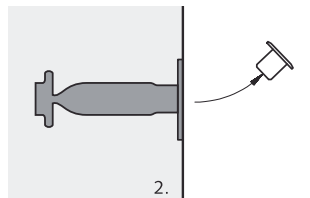

Remove formwork,
remove sealing cap

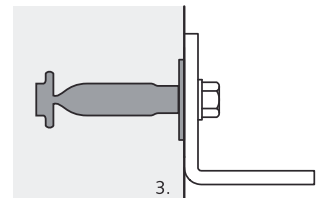

① Torque moment T_{inst} → see table on page 6

② Bending in the bolt has to be verified by the customer! (Bolt is not included in scope of delivery)

Assembly steps (shown: T-FIXX; fixing of other anchor types analogical)

Fixing to the formwork

Case D
with hexagonal bolt

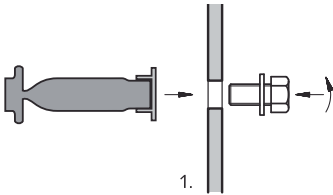

Preparing for assembly

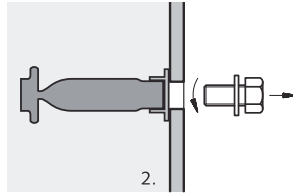

Screw-in and fixing of the bolt ①

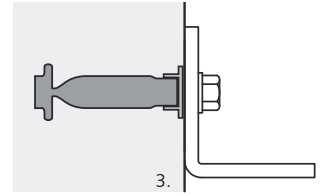

Unscrew hexagonal bolt,
remove formwork

Case E
with thread adapter and hexagonal bolt

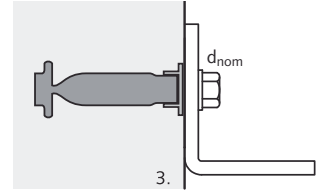
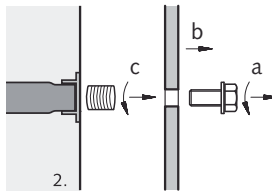
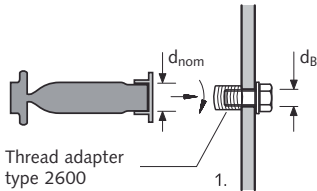

Assembly of thread adapter:
see page 3, figure 4

a) unscrew hexagonal bolt,
b) remove formwork,
c) thread adapter

Case F
with magnetic fixing plate on steel formwork

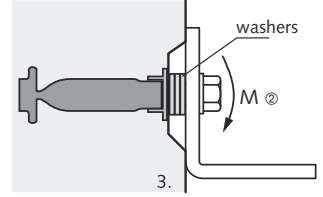
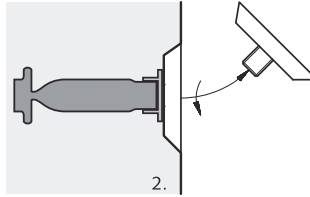
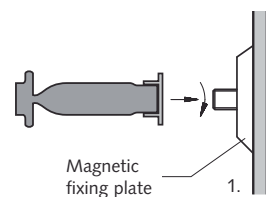

Remove formwork,
Unscrew magnetic fixing plate

① Torque moment T_{inst} → see table on page 6

② Bending in the bolt has to be verified the customer! (Bolt is not included in scope of delivery)

English

Deutsch

Français

Español

Nederlands

Polski

Torque moment T_{inst} [Nm]*			
Thread-size	T-FIXX®	Bolt anchors / Bar anchors	Socket anchors
M10	≤ 8	-	≤ 4
M12	≤ 10	≤ 10	≤ 8
M16	≤ 30	≤ 30	≤ 17
M20	≤ 60	≤ 50	≤ 25
M24	-	≤ 90	≤ 53
M30	-	≤ 180	≤ 96
M36	-	≤ 250	-
M42	-	≤ 300	-

* Tightening torque values apply only to bolts in unlubricated condition.

Determining bolt length

General

The fixture is attached to the cast-in anchor with a standard metric thread fastening bolt and washer or a threaded rod, a washer and a nut. The fixing components are not included with the HALFEN DEMU Fixing systems and have to be ordered separately. The fixing component (bolt) has to be selected according to the static engineer's specifications.

Screw-in length of bolt

For all fixing anchors there is a minimum and a maximum screw-in length. Minimum values can be found in the table below. The corresponding maximum values for each type can be found in the tables next page. To find the required bolt length, proceed as described below.

Determining the required bolt length (L_s)

Bolt length (L_s)
 $L_{s,min}$ = $s + k$ (minimum bolt length)
 $L_{s,max}$ = $a + k$ (maximum bolt length)

- k = clamp thickness (thickness of the steel angle support and the washers)
- s = minimum screw-in length (→ see table below)
- a = maximum screw-in length (→ see tables on page 7)

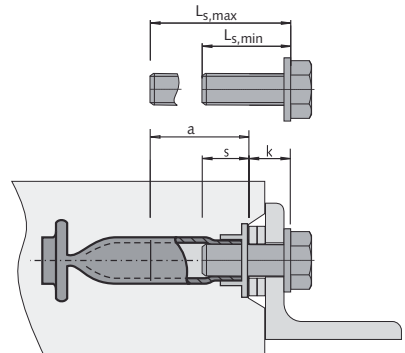

Minimum screw-in length s [mm]

Thread-size	T-FIXX®	Bolt anchor 1988	Bolt anchors 1985/1980-P / Bar anchors / Socket anchors ①,②
M6	-	-	7.2
M8	-	-	9.6
M10	17.0	-	12.0 / 15.0
M12	20.0	16.4	14.4 / 18.0
M16	26.0	21.2	19.2 / 24.0
M20	32.0	26.0	24.0 / 30.0
M24	-	30.8	28.8 / 36.0
M30	-	38.0	36.0
M36	-	45.2	43.2
M42	-	52.4	50.4

① value $s = 1.2 \times d_{nom}$
 ② higher values ($s = 1.5 \times d_{nom}$) apply for fixing anchors with integrated nailing plate
 → types 1985 (GV), 1036-G (GV, A4) and 1130 (GV).

Maximum screw-in length a [mm] for T-FIXX® ①		
Thread-size / anchor-type		a [mm]
M10	all types	32.0
M12	M 12 × 50	30.0
	M 12 × 70	28.0
	M 12 × 95	
	M 12 × 115	
M16	M 16 × 60	32.0
	M 16 × 80	50.0
	M 16 × 100	
	M 16 × 110	
	M 16 × 125	
M20	M 20 × 70	44.0
	M 20 × 100	62.0
	M 20 × 125	
	M 20 × 145	

① for type T-FIXX® (GV, A4)

Maximum screw-in length a [mm] for Bolt anchors / Bar anchors ②, ③	
Thread-size	a [mm]
M12	23.0
M16	29.0
M20	35.0
M24	46.0
M30	60.0
M36	74.0
M42	68.0

② for following types:

1985 (GV)
1980-P (GV, FV, A4-80)
3016 (GV)
3010 (A4-80)
1980-S (GV)
1988-S (GV)
1554 (GV, FV, A4-80)
1558 (GV, FV, A4-80)

Thread-size	4010/4030	1988*
	a [mm]	a [mm]
M12	-	25.0
M16	25.0	31.0
M20	33.0	37.0
M24	38.0	48.0
M30	48.0	62.0
M36	-	76.0
M42	65.0	70.0

③ for following types:

1988 (GV, FV, A4-50, A4-80)
4010 (GV, FV)
4030 (GV, FV)

* for bolt anchors with special sealing on bottom of the sleeve (types A4-50, A4-80), the values have to be decreased by 3.0 mm.

Maximum screw-in length a [mm] for Socket anchors ④-⑧		
Thread-size / anchor-type		a [mm]
M6	M 6 × 30	14.0
	M 6 × 40	20.0
M8	M 8 × 40	18.0
	M 8 × 50	25.0

④ for type 995-GB (GV)

Thread-size / anchor-type		a [mm]
M6	M 6 × 40	25.0

⑤ for type 995 (A4)

Thread-size / anchor-type		a [mm]
M8	M 8 × 50	20.0
M10	M 10 × 50	
M12	M 12 × 60 (GV)	23.0
	M 12 × 60 (A4)	25.0
	M 12 × 70	30.0
M16	M 16 × 70	25.0
	M 16 × 80	
	M 16 × 100 (A4)	32.0
	M 16 × 100 (GV)	
	M 16 × 120	
M20	M 20 × 100	40.0
	M 20 × 120	50.0
M24	M 24 × 120	
M30	M 30 × 150	

⑥ for following types:

995-G (GV, A4)
1036-G (GV, A4)

Thread-size / anchor-type		a [mm]
M8	M 8 × 50	30.0
M10	M 10 × 60	35.0
M12	M 12 × 45	18.0
	M 12 × 70	40.0
M16	M 16 × 60	24.0
	M 16 × 100	32.0
M20	M 20 × 70	30.0
	M 20 × 100	40.0
M24	M 24 × 80	24.0

⑦ for following types:

1130 (GV)
1140 (GV, A4)

Thread-size / anchor-type		a [mm]
M12	M 12 × 60	22.0
	M 16 × 75	22.0
M16	M 16 × 100	35.0
	M 20 × 90	25.0
M20	M 20 × 120	45.0
	M 24 × 100	30.0
M30	M 30 × 135	35.0

⑧ for type 995-DG (GV)

Ankertypen

Diese Montageanleitung ist für folgende Ankertypen der DEMU Hülseanker gültig:

T-FIXX®
(GV, A4)

**Bolzenanker**

Typen 1988 (GV, FV, A4-50, A4-80), 1985 (GV), 1980-P (GV, FV, A4-80)

**Stabanker**

Typen 4010 (GV, FV), 4030 (GV, FV), 3016 (GV), 3010 (A4-80), 1980-S (GV), 1988-S (GV), 1554 (GV, FV, A4-80), 1558 (GV, FV, A4-80)

**Ankerhülsen**

Typen 995-GB (GV), 995 (A4), 995-G (GV, A4), 995-DG (GV), 1036-G (GV, A4), 1130 (GV), 1140 (GV, A4)



Allgemeine Einbauhinweise

Damit ein sauberer Verbund zwischen Hülseanker und Beton gewährleistet werden kann, ist sicherzustellen, dass der Anker nicht mit Fremdkörpern, Öl, etc. verschmutzt ist. Der Beton sollte sorgsam eingebracht werden, der direkte Kontakt zwischen Rüttler und Anker ist zu vermeiden. Zusätzliches Anrödeln der Anker an die Bewehrung ist zu empfehlen.

Hülseanker können oberflächenbündig oder vertieft eingebaut werden. Im Fall von zurückversetzt eingebauten Ankern sind bei Befestigung des Anbauteils Unterlegscheiben zur Unterfütterung zu verwenden.

Unmittelbar nach dem Ausschalen sollten die Nagelteller herausgedreht werden. **Das Innere der Gewindehülse hat dann bis zur Verwendung, d. h. bis zur Befestigung des**

Anbauteils, gegen Eindringen von Wasser, Verunreinigungen oder Öl geschützt zu werden und trocken zu sein. Auch nach der Endmontage ist sicherzustellen, dass kein Wasser in die Gewindehülse eindringt.

Zur Befestigung des Anbauteils sind die in den Konstruktionsunterlagen des verantwortlichen Planers vorgeschriebenen Schrauben zu verwenden.

Die minimalen / maximalen Einschraubtiefen der Befestigungsschrauben in die Gewindehülsen sowie die maximalen Installationsdrehmomente (T_{inst}) sind gemäß den Tabellen auf den Seiten 12 - 13 einzuhalten.

Die Belastung des Hülseankers darf erst nach Erreichen der vorgesehenen Betonfestigkeit erfolgen.

Schweißbarkeit

Alle im Katalog „DEMU-FIX“ aufgeführten HALFEN DEMU-Produkte (aus Stahl) sind grundsätzlich schweißbar. Allerdings kann jede Form von Schweißen, einschließlich Heftschweißen, die mechanischen Eigenschaften der HALFEN DEMU-Produkte beeinträchtigen.

Sollte sich in speziellen Anwendungsfällen Schweißen nicht vermeiden lassen, so ist folgendes unbedingt zu beachten:

- Eingeschränkte Funktionsfähigkeit sowie verminderte Tragfähigkeit können eintreten.
- Evtl. vorhandene Beschichtungen sind vor dem Schweißen zu entfernen; durch den Schweißvorgang auftretende Dämpfe sind mit geeignetem Gerät abzusaugen.
- Es ist die vorgeschriebene Schutzausrüstung zu tragen.
- Der Kunde ist verantwortlich für die Einhaltung der geltenden Vorschriften bzgl. des Schweißvorgangs.

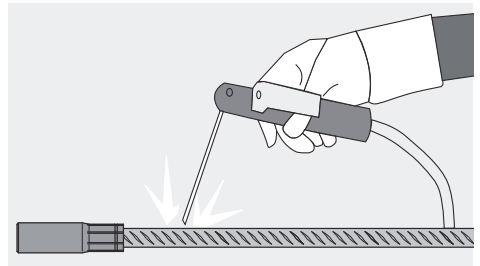

Leviat übernimmt keinerlei Haftung für Schäden durch HALFEN DEMU-Produkte bzw. an HALFEN DEMU-Produkten, die geschweißt wurden.

Montage des Zubehörs

Haltescheibe

Typ 2275 (h=2 mm)



Typ 2280 (h=10 mm)



Montage-Bruchdübel

Typ 2250



Verschlussstopfen

Typ 2244



Gewindeadapter

Typ 2600



Verfügbare Gewindegrößen: M8 – M30

d_{nom}	M8*	M10	M12	M16	M20	M24	M30*
-----------	-----	-----	-----	-----	-----	-----	------

* nur Typ 2280 lieferbar

Abbildung 1

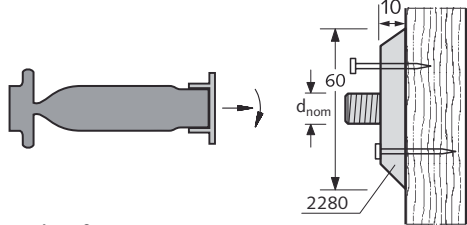

Verfügbare Gewindegrößen: M6 – M24

d_{nom}	M6	M8	M10	M12	M16	M20	M24
\varnothing Bohrloch [mm]	11	11	11	11	17	17	17

Abbildung 2

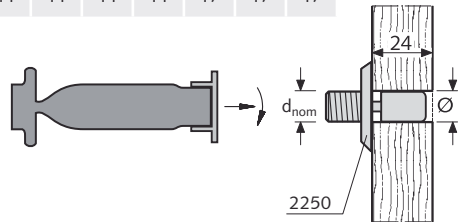

Verfügbare Gewindegrößen: M6 – M42

d_{nom}	M6	M8	M10	M12	M16	M20	M24	M30	M36	M42
-----------	----	----	-----	-----	-----	-----	-----	-----	-----	-----

Abbildung 3

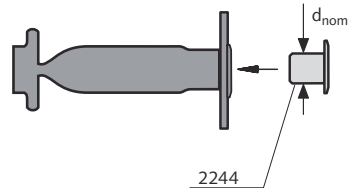

Verfügbare Gewindegrößen: M12 – M42

d_{nom}	M12	M16	M20	M24	M30	M36	M42
d_B Schraube	M6	M8	M8	M10	M10	M10	M12

Abbildung 4

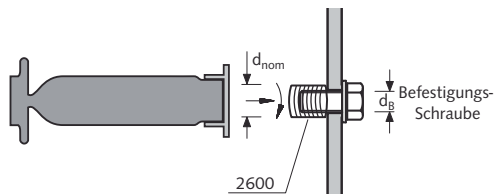

Montagschritte (Abbildung: T-FIXX; Befestigung der anderen Hülseankertypen analog)

Befestigung an der Schalung

Vorbereitung zur Montage

Schraube eindrehen und festziehen ①

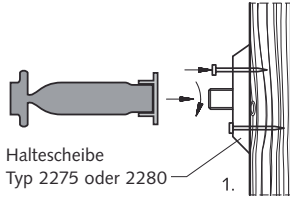
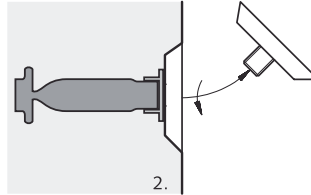
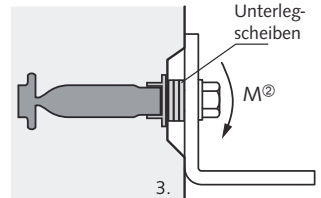
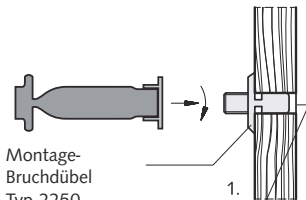
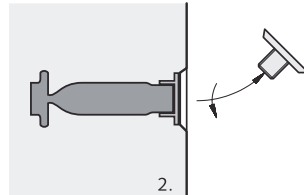
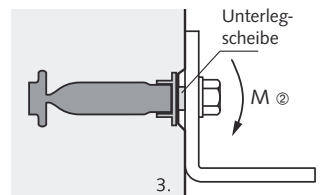
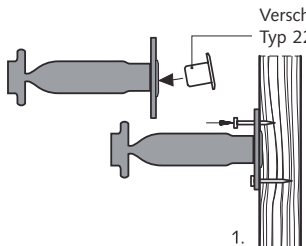
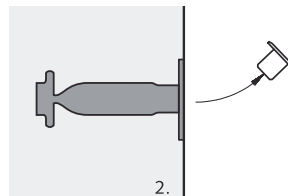
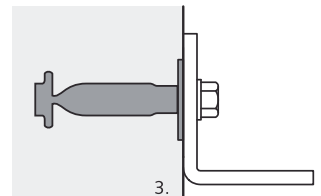
Fall A
mit Kunststoff-HaltescheibeHaltescheibe
Typ 2275 oder 2280Haltescheibe festnageln:
siehe Seite 9, Abbildung 1Schalung entfernen,
Haltescheibe herausdrehenFall B
mit Montage-BruchdübelMontage-
Bruchdübel
Typ 2250Bohrloch in Schalung:
siehe Seite 9, Abbildung 2Schalung entfernen,
Gewindeteil herausdrehenFall C
Hülseanker mit integriertem NagelflanschVerschlussstopfen
Typ 2244Verschlussstopfen in Hülseanker
einsetzen:
siehe Seite 9, Abbildung 3Schalung entfernen,
Verschlussstopfen entfernen① Anzugsdrehmomente T_{inst} → siehe Tabelle auf Seite 12

② Schraubenbiegung infolge der rückversetzten Lage des Hülseankers ist zu berücksichtigen und bauseits nachzuweisen (Schrauben nicht im Lieferumfang enthalten)

Montagschritte (Abbildung: T-FIXX; Befestigung der anderen Hülseankertypen analog)

Befestigung an der Schalung

Vorbereitung zur Montage

Schraube eindrehen und festziehen ①

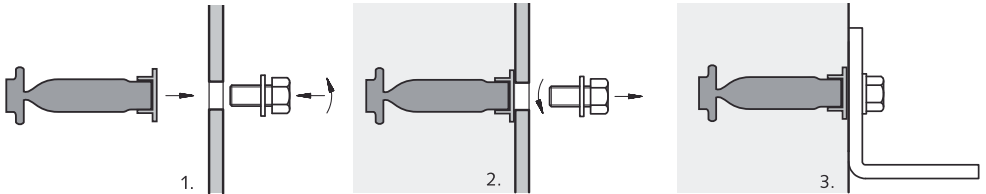
Fall D
mit Sechskantschraube

Sechskantschraube herausdrehen,
Schalung entfernen

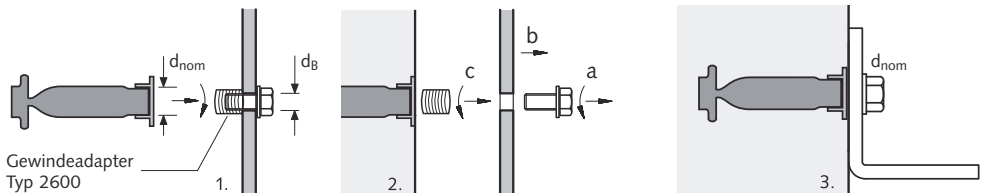
Fall E
mit Gewindeadapter und Sechskantschraube

Gewindeadapter fixieren:
siehe Seite 9, Abbildung 4

a) Sechskantschraube herausdrehen,
b) Schalung entfernen,
c) Gewindeadapter herausdrehen

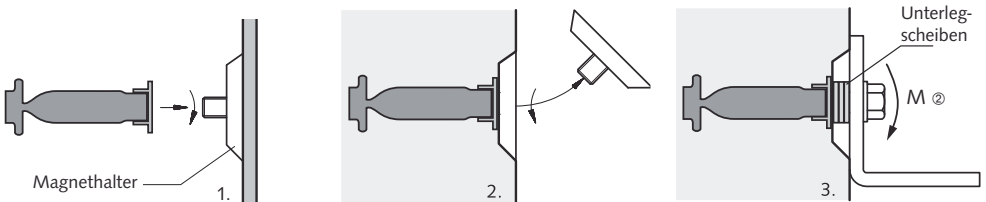
Fall F
mit Magnethalter auf Stahlschalung

Schalung entfernen,
Magnethalter herausdrehen

① Anzugsdrehmomente T_{inst} → siehe Tabelle auf Seite 12

② Schraubenbiegung infolge der rückversetzten Lage des Hülseankers ist zu berücksichtigen und bauseits nachzuweisen (Schrauben nicht im Lieferumfang enthalten)

Drehmoment T_{inst} [Nm]*			
Gewindegröße	T-FIXX®	Bolzenanker / Stabanker	Ankerhülse
M10	≤ 8	-	≤ 4
M12	≤ 10	≤ 10	≤ 8
M16	≤ 30	≤ 30	≤ 17
M20	≤ 60	≤ 50	≤ 25
M24	-	≤ 90	≤ 53
M30	-	≤ 180	≤ 96
M36	-	≤ 250	-
M42	-	≤ 300	-

* Die Anzugsmomente gelten nur für Schrauben im ungeschmierten Zustand.

Ermittlung der erforderlichen Schraubenlänge

Allgemeines

Das Einbauteil wird mit einer Befestigungsschraube mit metrischem Regalgewinde und Unterlegscheibe bzw. mit Gewindestange, Unterlegscheibe und Kontermutter im einbetonierten Hülseanker befestigt. Die genannten Befestigungskomponenten sind nicht im Lieferumfang enthalten und müssen separat bestellt bzw. vorgehalten werden. Es sind Schrauben gemäß den Vorgaben des verantwortlichen Planers zu verwenden.

Einschraublänge

Bei der Verwendung der Hülseanker sind die minimalen und maximalen Einschraublängen zu beachten. Die Mindesteinschraublängen sind in der Tabelle unten zusammengefasst. Die entsprechenden maximalen Werte sind den Tabellen auf der folgenden Seite zu entnehmen. Die Ermittlung der erforderlichen Schraubenlängen ist im folgenden Abschnitt beschrieben.

Ermittlung der erforderlichen Schraubenlänge (L_s)

Schraubenlänge (L_s)

$$L_{s,min} = s + k \text{ (minimale Schraubenlänge)}$$

$$L_{s,max} = a + k \text{ (maximale Schraubenlänge)}$$

- k = Klemmdicke
 (Dicke des Anbauteils und der Unterlegscheiben)
 s = minimale Einschraublänge (→ siehe Tabelle unten)
 a = maximale Einschraublänge (→ siehe Tabellen auf Seite 13)

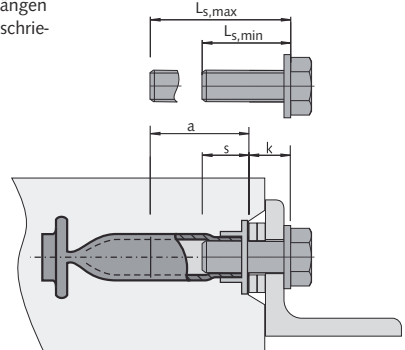

Minimale Einschraublänge s [mm]

Gewindegröße	T-FIXX®	Bolzenanker 1988	Bolzenanker 1985/1980-P / Stabanker / Ankerhülse ①,②
M6	-	-	7,2
M8	-	-	9,6
M10	17,0	-	12,0 / 15,0
M12	19,0	16,4	14,4 / 18,0
M16	26,0	21,2	19,2 / 24,0
M20	32,0	26,0	24,0 / 30,0
M24	-	30,8	28,8 / 36,0
M30	-	38,0	36,0
M36	-	45,2	43,2
M42	-	52,4	50,4

① $s = 1,2 \times d_{nom}$

② größere Werte ($s = 1,5 \times d_{nom}$) gelten für Hülseanker mit integriertem Nagelflansch
 → Typen 1985 (GV), 1036-G (GV, A4) und 1130 (GV).

Maximale Einschraublänge a [mm] für T-FIXX® ①		
Gewindegröße / Ankerabmessung		a [mm]
M10	alle Größen	32,0
	M 12 × 50	30,0
M12	M 12 × 70	28,0
	M 12 × 95	
	M 12 × 115	
M16	M 16 × 60	32,0
	M 16 × 80	50,0
	M 16 × 100	
	M 16 × 110	
	M 16 × 125	
M 20 × 70	44,0	
M20	M 20 × 100	62,0
	M 20 × 125	
	M 20 × 145	

① für Typ T-FIXX® (GV, A4)

Maximale Einschraublänge a [mm] für Bolzenanker / Stabanker ②,③	
Gewindegröße	a [mm]
M12	23,0
M16	29,0
M20	35,0
M24	46,0
M30	60,0
M36	74,0
M42	68,0

② für folgende Typen:

1985 (GV)
1980-P (GV, FV, A4-80)
3016 (GV)
3010 (A4-80)
1980-S (GV)
1988-S (GV)
1554 (GV, FV, A4-80)
1558 (GV, FV, A4-80)

Gewindegröße	4010/4030	1988*
	a [mm]	a [mm]
M12	-	25,0
M16	25,0	31,0
M20	33,0	37,0
M24	38,0	48,0
M30	48,0	62,0
M36	-	76,0
M42	65,0	70,0

③ für folgende Typen:

1988 (GV, FV, A4-50, A4-80)
4010 (GV, FV)
4030 (GV, FV)

* Für Bolzenanker mit versiegeltem Hülseboden (Typen A4-50, A4-80) sind die Werte um 3 mm abzumindern.

Maximale Einschraublänge a [mm] für Ankerhülsen ④-⑥		
Gewindegröße / Ankerabmessung		a [mm]
M6	M 6 × 30	14,0
	M 6 × 40	20,0
M8	M 8 × 40	18,0
	M 8 × 50	25,0

④ für Typ 995-GB (GV)

Gewindegröße / Ankerabmessung		a [mm]
M6	M 6 × 40	25,0

⑤ für Typ 995 (A4)

Gewindegröße / Ankerabmessung		a [mm]
M8	M 8 × 50	20,0
M10	M 10 × 50	
M12	M 12 × 60 (GV)	23,0
	M 12 × 60 (A4)	25,0
	M 12 × 70	30,0
M16	M 16 × 70	25,0
	M 16 × 80	
	M 16 × 100 (A4)	
	M 16 × 100 (GV)	
	M 16 × 120	
M20	M 20 × 100	40,0
	M 20 × 120	40,0
M24	M 24 × 120	50,0
M30	M 30 × 150	70,0

⑥ für folgende Typen:

995-G (GV, A4)
1036-G (GV, A4)

Gewindegröße / Ankerabmessung		a [mm]
M8	M 8 × 50	30,0
M10	M 10 × 60	35,0
M12	M 12 × 45	18,0
	M 12 × 70	40,0
M16	M 16 × 60	24,0
	M 16 × 100	32,0
M20	M 20 × 70	30,0
	M 20 × 100	40,0
M24	M 24 × 80	24,0

⑦ für folgende Typen:

1130 (GV)
1140 (GV, A4)

Gewindegröße / Ankerabmessung		a [mm]
M12	M 12 × 60	22,0
	M 16 × 75	22,0
M16	M 16 × 100	35,0
	M 20 × 90	25,0
M20	M 20 × 120	45,0
	M 24 × 100	30,0
M30	M 30 × 135	35,0

⑧ für Typ 995-DG (GV)

Types de douilles

Ces instructions d'utilisation sont valables pour les douilles de fixation DEMU figurant ci-dessous :

T-FIXX®
 (GV, A4)

Douilles à barre d'ancrage

Types 4010 (GV, FV), 4030 (GV, FV), 3016 (GV), 3010 (A4-80), 1980-S (GV), 1988-S (GV), 1554 (GV, FV, A4-80), 1558 (GV, FV, A4-80)

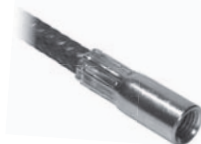
Douilles à pied d'ancrage

Types 1988 (GV, FV, A4-50, A4-80), 1985 (GV), 1980-P (GV, FV, A4-80)

Douilles de fixation

Types 995-GB (GV), 995 (A4), 995-G (GV, A4), 995-DG (GV), 1036-G (GV, A4), 1130 (GV), 1140 (GV, A4)



Informations générales pour l'utilisation

Afin de garantir la meilleure adhérence possible entre la douille de fixation et le béton, assurez vous que la surface de la douille soit propre et exempte de poussière ou d'huile.

Le béton doit être coulé avec précaution, éviter le contact direct entre les douilles de fixation et les outils de compactage. Nous recommandons une sécurité supplémentaire en liaissant solidement les douilles au coffrage.

La douille de fixation peut être facilement noyée dans le béton. Nous recommandons fortement l'utilisation de plaques de fixations ou l'un des accessoires de la page 15. Les fixations des douilles doivent être retirées rapidement après le décoffrage.

Le filetage intérieur de la douille doit être séché et à nouveau protégé avec un bouchon contre les agressions possibles telles que l'eau, la poussière et l'huile. Aussi après l'assemblage final il faut assurer que l'intérieur de la douille reste sec.

Le boulon ou la vis (pas métrique standard) pour la fixation de l'élément doit être choisi en fonction des calculs et des spécifications du bureau d'ingénierie. Les profondeurs minimales / maximales de vissage pour les boulons et le couple de serrage (T_{inst}) figurent en pages 18-19.

La douille de fixation ne doit pas être soumise à sa capacité de charge complète avant que le béton n'ait atteint sa résistance finale.

Soudure

Tous les produits HALFEN DEMU dans notre catalogue technique «Douilles de fixation DEMU» peuvent être soudés par points. Toutefois, toute soudure, notamment les soudures de positionnement, peuvent influencer négativement les propriétés mécaniques des douilles. Souder peut affecter les performances d'un produit.

Si pour votre utilisation il est impossible d'éviter toute soudure, il faut tenir compte des éléments suivants :

- une possible modification des performances et une possible réduction des capacités de charge
- enlever le revêtement de protection (galva...) avant de commencer à souder et assurez vous que les fumées de soudures sont correctement évacuées pendant la soudure.
- utiliser les équipements de protection appropriés le client doit s'assurer que la soudure est conforme aux recommandations réglementaires sur les soudures.

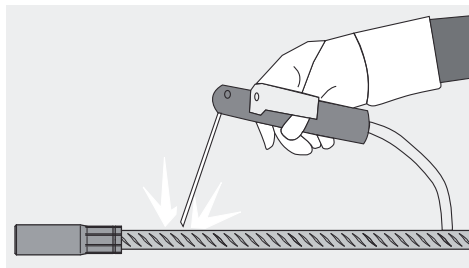

Leviant ne pourrait être tenu responsable pour tout dommage causé à ou par des douilles HALFEN DEMU qui ont été soudées.

Utilisation des accessoires

Fixation plastique

Type 2275 (h=2 mm)



Type 2280 (h=10 mm)



Téton de fixation

Type 2250



Bouchon plastique

Type 2244



Réducteur de fixation

Type 2600



Diamètres des filetages disponibles : M8 – M30

d_{nom}	M8*	M10	M12	M16	M20	M24	M30*
-----------	-----	-----	-----	-----	-----	-----	------

* seul le type 2280 est disponible

Figure 1

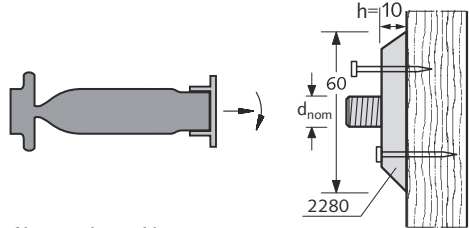

Diamètres des filetages disponibles : M6 – M24

d_{nom}	M6	M8	M10	M12	M16	M20	M24
\varnothing trou de perçage [mm]	11	11	11	11	17	17	17

Figure 2

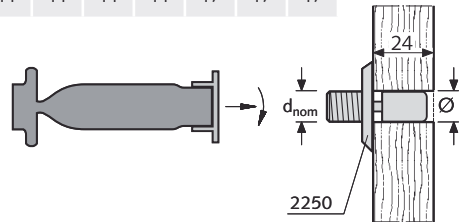

Diamètres des filetages disponibles : M6 – M42

d_{nom}	M6	M8	M10	M12	M16	M20	M24	M30	M36	M42
-----------	----	----	-----	-----	-----	-----	-----	-----	-----	-----

Figure 3

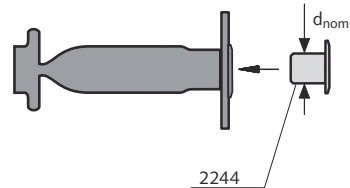

Diamètres des filetages disponibles : M12 – M42

d_{nom}	M12	M16	M20	M24	M30	M36	M42
d_B diamètre de la vis	M6	M8	M8	M10	M10	M10	M12

Figure 4

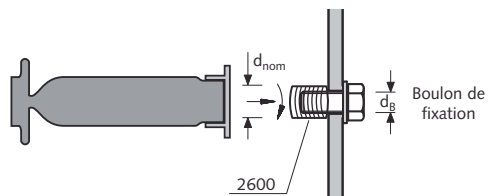

Étapes de la mise en place (exemple avec T-FIXX; fixation des autres douilles de façon identique)

Fixation au coffrage

Démontage pour le préparation de l'assemblage final

Vissage et fixation de la vis ①

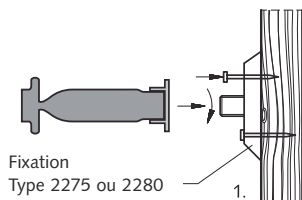
Cas A
avec fixation en plastique à clouer

Mise en place de la fixation
voir page 15, figure 1

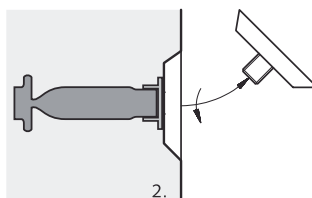

Enlever le coffrage,
dévisser la fixation en plastique

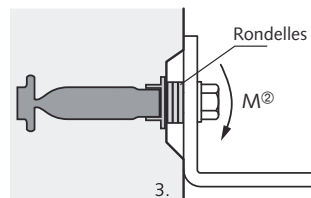
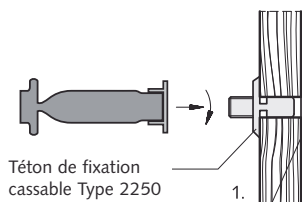
Cas B
avec téton de fixation cassable

Trou percé dans le coffrage:
voir page 15, figure 2

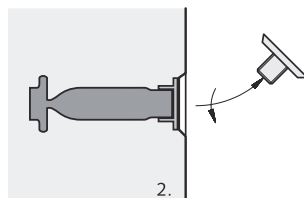

Enlever le coffrage,
dévisser le reste du téton

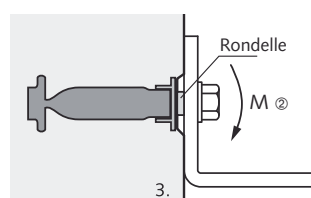
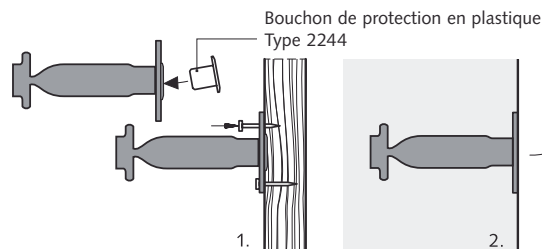
Cas C
Douille de fixation avec collerette de fixation

Fixation du bouchon d'étanchéité
voir page 15, figure 3

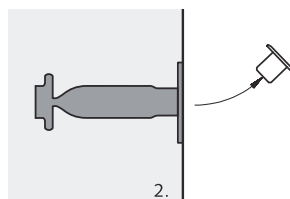

Enlever le coffrage,
enlever le bouchon d'étanchéité

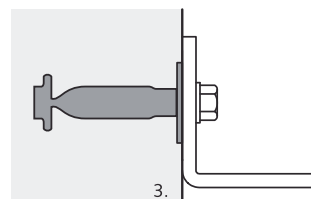

① Couple de serrage T_{inst} → voir tableau en page 18

② La flexion de la vis doit être vérifiée par le client ! (La vis de fixation ne fait partie des fournitures des douilles de fixation)

Étapes de la mise en place (exemple avec T-FIXX; fixation des autres douilles de façon identique)

Fixation au coffrage

Cas D
avec une vis à tête hexagonale

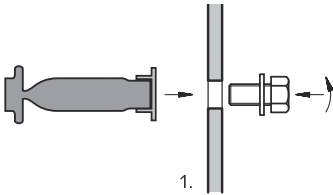

Démontage pour le préparation de l'assemblage final

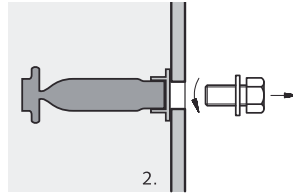

Vissage et fixation de la vis ①

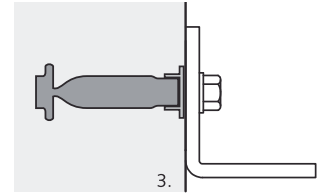

Dévisser la vis à tête hexagonale, enlever le coffrage

Cas E
avec réducteur de filetage et vis à tête hexagonale

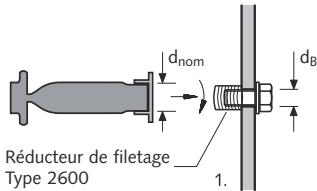

Réducteur de filetage Type 2600

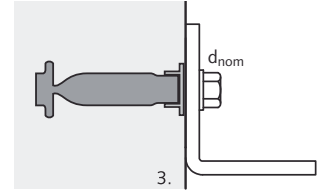
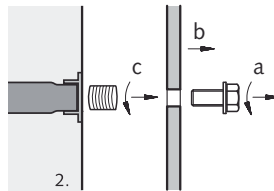

Mise en place de l'adaptateur: voir page 15, figure 4

a) dévisser la vis à tête hexagonale,
b) enlever le coffrage,
c) dévisser le réducteur

Cas F
avec fixation magnétique sur coffrage en acier

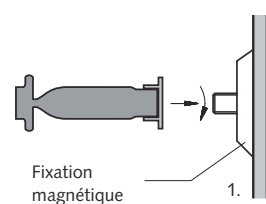

Fixation magnétique

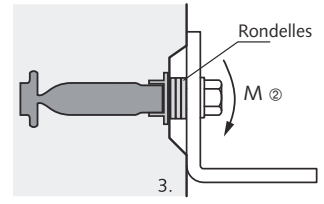
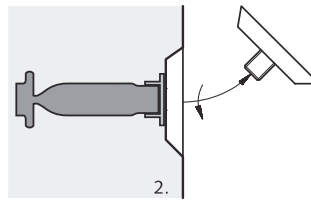

Enlever le coffrage, dévisser la fixation magnétique

① Couple de serrage T_{inst} → voir tableau en page 18

② La flexion de la vis doit être vérifiée par le client ! (La vis de fixation ne fait partie des fournitures des douilles de fixation)

Couple de serrage T_{inst} [Nm]*

Filetage	T-FIXX®	Douille à barre d'ancrage / Douille à vis d'ancrage	Douille de fixation
M10	≤ 8	-	≤ 4
M12	≤ 10	≤ 10	≤ 8
M16	≤ 30	≤ 30	≤ 17
M20	≤ 60	≤ 50	≤ 25
M24	-	≤ 90	≤ 53
M30	-	≤ 180	≤ 96
M36	-	≤ 250	-
M42	-	≤ 300	-

* Les couples de serrage sont uniquement valables pour des boulons non lubrifiés.

Détermination de la longueur de la vis

Généralités

Les éléments de fixation sont liaisonnés à la douille de fixation par l'intermédiaire d'une vis à filetage métrique standard et de rondelles ou d'une tige filetée, d'une rondelle et d'un écrou. Les éléments de fixation ne font pas partis du système de fixation HALFEN DEMU et doivent être commandés séparément. L'élément de fixation (la vis) doit être choisie suivant les recommandations du bureau d'ingénierie.

Profondeur de vissage de la vis

Pour toutes les douilles de fixations, il y a une profondeur de vissage minimale et maximale. Les valeurs minimales sont données dans le tableau ci-dessous. Les valeurs maximales correspondantes pour chaque modèle sont données dans les tableaux de la page suivante. Pour trouver la longueur de la vis recommandée, procédez comme expliqué ci-dessous.

Détermination de la longueur de la vis (L_s)Longueur de la vis (L_s)

$$L_{s,min} = s + k \text{ (profondeur à visser minimale)}$$

$$L_{s,max} = a + k \text{ (profondeur à visser maximale)}$$

- k = Épaisseur à pincer (épaisseur de l'élément fixé et des rondelles)
 s = profondeur à visser minimale (→ voir tableau ci-dessous)
 a = profondeur à visser maximale (→ voir tableau en page 19)

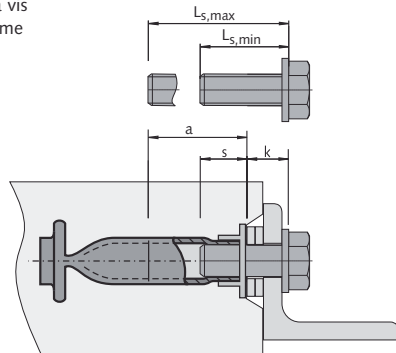
Profondeurs de vissage minimales s [mm]

Filetage	T-FIXX®	Douille de fixation 1988	Douille de fixation 1985/1980-P / Douille à barre d'ancrage / Douille à vis d'ancrage ①,②
M6	-	-	7,2
M8	-	-	9,6
M10	17,0	-	12,0 / 15,0
M12	20,0	16,4	14,4 / 18,0
M16	26,0	21,2	19,2 / 24,0
M20	32,0	26,0	24,0 / 30,0
M24	-	30,8	28,8 / 36,0
M30	-	38,0	36,0
M36	-	45,2	43,2
M42	-	52,4	50,4

① $s = 1,2 \times d_{nom}$

② Des valeurs plus importantes ($s = 1,5 \times d_{nom}$) s'appliquent pour des douilles avec une collerette de fixation → types 1985 (GV), 1036-G (GV, A4) et 1130 (GV).

Profondeur maximale de vissage a [mm] pour T-FIXX® ①		
Filetage / type de douille	a [mm]	
M10	Toutes dimensions	32,0
M12	M 12 × 50	30,0
	M 12 × 70	28,0
	M 12 × 95	
	M 12 × 115	
M 16 × 60	32,0	
M16	M 16 × 80	50,0
	M 16 × 100	
	M 16 × 110	
	M 16 × 125	
M20	M20 × 70	44,0
	M20 × 100	62,0
	M20 × 125	
	M20 × 145	

① pour douille type T-FIXX® (GV, A4)

Profondeur maximale de vissage a [mm] pour douilles à vis / à barre d'ancrage ② et ③	
Filetage	a [mm]
M12	23,0
M16	29,0
M20	35,0
M24	46,0
M30	60,0
M36	74,0
M42	68,0

② pour les types de douilles suivants:
 1985 (GV)
 1980-P (GV, FV, A4-80)
 3016 (GV)
 3010 (A4-80)
 1980-S (GV)
 1988-S (GV)
 1554 (GV, FV, A4-80)
 1558 (GV, FV, A4-80)

Filetage	4010/4030	1988*
	a [mm]	a [mm]
M12	-	25,0
M16	25,0	31,0
M20	33,0	37,0
M24	38,0	48,0
M30	48,0	62,0
M36	-	76,0
M42	65,0	70,0

③ pour les types de douilles suivants:

1988 (GV, FV, A4-50, A4-80)
 4010 (GV, FV)
 4030 (GV, FV)

* Pour les douilles à vis d'ancrage avec une couche d'étanchéité en dessous du manchon, les valeurs doivent être réduites de 3,0 mm.

Profondeur maximale de vissage a [mm] pour les douilles de fixation ④-⑥		
Filetage / type de douille	a [mm]	
M6	M 6 × 30	14,0
	M 6 × 40	20,0
M8	M 8 × 40	18,0
	M 8 × 50	25,0

④ pour douille type 995-GB (GV)

Filetage / type de douille	a [mm]	
M6	M 6 × 40	25,0

⑤ pour douille type 995 (A4)

Filetage / type de douille	a [mm]	
M8	M 8 × 50	20,0
M10	M 10 × 50	
M12	M 12 × 60 (GV)	23,0
	M 12 × 60 (A4)	25,0
	M 12 × 70	30,0
M16	M 16 × 70	25,0
	M 16 × 80	
	M 16 × 100 (A4)	32,0
	M 16 × 100 (GV)	
	M 16 × 120	
M20	M 20 × 100	40,0
	M 20 × 120	
M24	M 24 × 120	50,0
M30	M 30 × 150	70,0

⑥ pour les types de douilles suivants:

995-G (GV, A4)
 1036-G (GV, A4)

Filetage / type de douille	a [mm]	
M8	M 8 × 50	30,0
M10	M 10 × 60	35,0
M12	M 12 × 45	18,0
	M 12 × 70	40,0
M16	M 16 × 60	24,0
	M 16 × 100	32,0
M20	M 20 × 70	30,0
	M 20 × 100	40,0
M24	M 24 × 80	24,0

⑦ pour les types de douilles suivants:

1130 (GV)
 1140 (GV, A4)

Filetage / type de douille	a [mm]	
M12	M 12 × 60	22,0
	M 16 × 75	22,0
M16	M 16 × 100	35,0
	M 20 × 90	25,0
M20	M 20 × 120	45,0
	M 24 × 100	30,0
M30	M 30 × 135	35,0

⑧ pour douille type 995-DG (GV)

Tipo de fijaciones

Estas instrucciones de montaje son válidas para los siguientes modelos de Casquillos HALFEN DEMU:

T-FIX®
(GV, A4)



Casquillo de fijación tipo tornillo

modelo 1988 (GV, FV, A4-50, A4-80), 1985 (GV), 1980-P (GV, FV, A4-80)



Casquillo de fijación tipo barra

modelo 4010 (GV, FV), 4030 (GV, FV), 3016 (GV), 3010 (A4-80), 1980-S (GV), 1988-S (GV), 1554 (GV, FV, A4-80), 1558 (GV, FV, A4-80)



Casquillo de fijación con agujero

modelo 995-GB (GV), 995 (A4), 995-G (GV, A4), 995-DG (GV), 1036-G (GV, A4), 1130 (GV), 1140 (GV, A4)



Notas generales para la instalación

Para garantizar la mejor unión posible entre el anclaje de fijación y el hormigón, asegúrese de que la superficie del anclaje esté libre de suciedad, aceite, etc.

El hormigón tiene que ser vertido con cuidado; evite el contacto directo entre el vibrador y el casquillo de fijación. Se recomienda asegurar adicionalmente los anclajes mediante atado de cables.

Los casquillos de fijación se pueden instalar al ras o rehundidos. Para los anclajes rehundidos se debe usar un plato de fijación.

Rápidamente después de quitar el encofrado debería de retirar los platos de fijación. **El interior de la rosca debe estar seco y además protegido contra la entrada de agua,**

polvo o grasa hasta que vaya a ser usado ej. por elementos de fijación. Puede utilizar unos tapones. Asegúrese de que el interior del casquillo permanezca seco después del ensamblaje final.

El elemento de fijación (perno / tornillo con rosca métrica estándar) debe seleccionarse de acuerdo con las especificaciones del ingeniero. La longitud de atornillado mínima / máxima para los pernos y el par de apriete (T_{inst}) se encuentran en las páginas 24 - 25.

El anclaje de fijación no debe estar sujeto a la capacidad de carga completa hasta que el hormigón haya alcanzado su resistencia final.

Soldadura

Todos los productos HALFEN DEMU (hechos de acero) enumerados en el catálogo „DEMU-FIX“ son básicamente soldables. Sin embargo, cualquier forma de soldadura, incluida la soldadura por puntos, puede afectar las propiedades mecánicas de los productos HALFEN DEMU.

Si la soldadura en la aplicación es inevitable, tenga en cuenta lo siguiente:

- un posible cambio en el rendimiento; una posible reducción en la capacidad de carga
- elimine cualquier capa de recubrimiento antes de soldar, y asegúrese de que los humos de soldadura se extraigan con seguridad durante la soldadura
- usar equipo de protección obligatorio
- el cliente es responsable de asegurarse de que se respeten las normas de soldadura aplicables

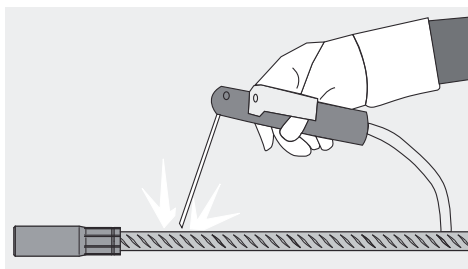

Leviant no asume ninguna responsabilidad por daños causados por productos HALFEN DEMU o productos HALFEN DEMU que hayan sido soldados.

Accesorios de montaje

Plato para clavar

Tipo 2275 (h=2 mm)



Tipo 2280 (h=10 mm)



Pin para fijación

Tipo 2250



Métricas disponibles: M8 – M30

d_{nom}	M8*	M10	M12	M16	M20	M24	M30*
-----------	-----	-----	-----	-----	-----	-----	------

* Solamente disponible para tipo 2280

Figura 1

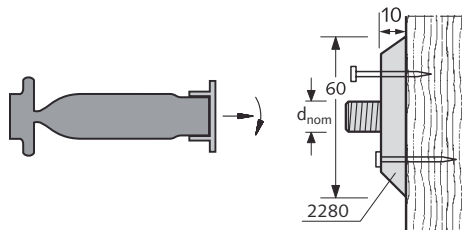

Métricas disponibles: M6 – M24

d_{nom}	M6	M8	M10	M12	M16	M20	M24
\varnothing agujero perforación [mm]	11	11	11	11	17	17	17

Figura 2

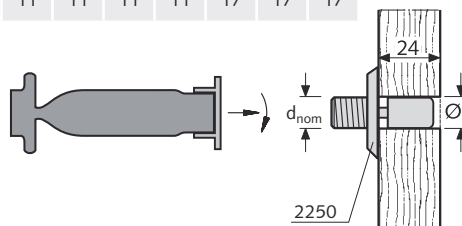

Tapón de sellado

Tipo 2244



Métricas disponibles: M6 – M42

d_{nom}	M6	M8	M10	M12	M16	M20	M24	M30	M36	M42
-----------	----	----	-----	-----	-----	-----	-----	-----	-----	-----

Figura 3

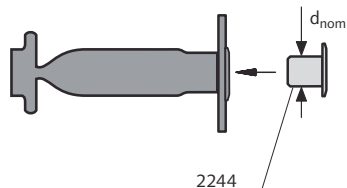

Adaptador de rosca

Tipo 2600



Métricas disponibles: M12 – M42

d_{nom}	M12	M16	M20	M24	M30	M36	M42
d_B tornillo para fijación	M6	M8	M8	M10	M10	M10	M12

Figura 4

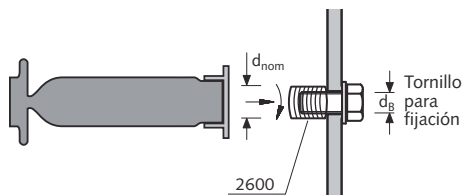

Pasos para montaje (Ver: T-FIXX; fijación con otros tipos similares)

Fijación al encofrado

Preparación para montaje

Atornillar y fijar el tornillo ①

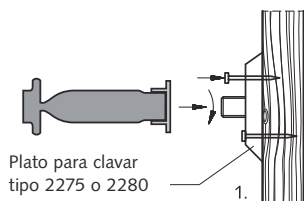
Caso A
con plato de plástico

Montaje del plato:
ver pag. 21, figura 1

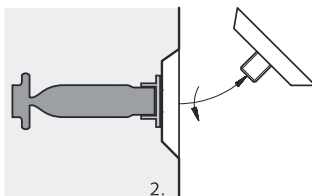

Retirar el encofrado,
desenroscar el plato

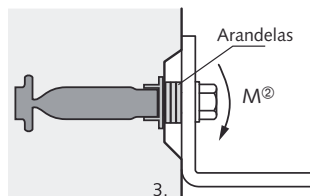
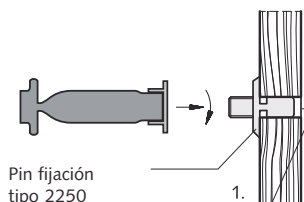
Caso B
con Pin de fijación

Taladro en el encofrado:
ver pag. 21, figura 2

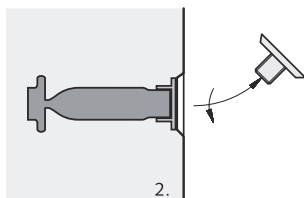

Retirar el encofrado,
desenroscar el resto del pin

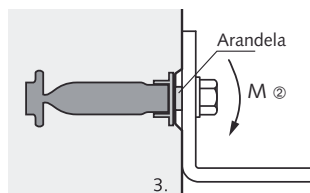
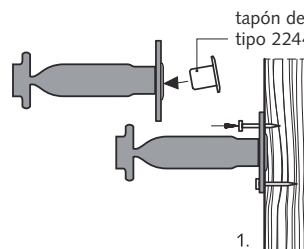
Caso C
Casquillos de fijación con corona, para fijación, integrada

Insertar el tapón:
ver pag. 21, figura 3

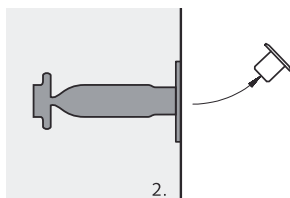

Retirar el encofrado,
retirar el tapón

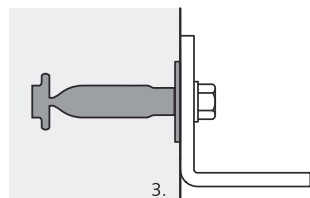

① Par de Apriete T_{inst} → ver tabla pag. 25

② El Momento transmitido al tornillo debe ser verificado por el cliente (tornillos no incluidos)

Pasos para montaje (Ver: T-FIXX; fijación con otros tipos similares)

Fijación al encofrado

Preparación para montaje

Atornillar y fijar el tornillo ①

Caso D
con tornillo hexagonal

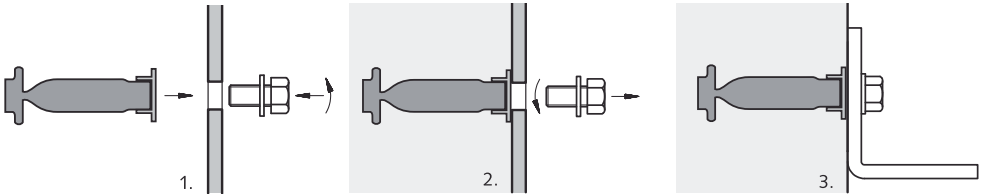

Desenroscar el tornillo hexagonal,
retirar el encofrado

Caso E
con adaptador de rosca y tornillo hexagonal

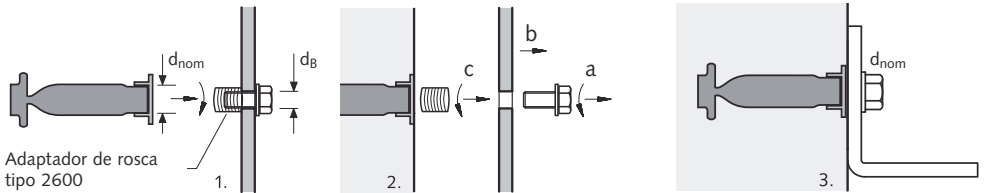

Adaptador de rosca
tipo 2600

Montaje del adaptador:
ver pág. 21, figura 4

a) Desenroscar el tornillo hexagonal,
b) retirar el encofrado,
c) retirar el adaptador

Caso F
con plato magnético para encofrado metálico

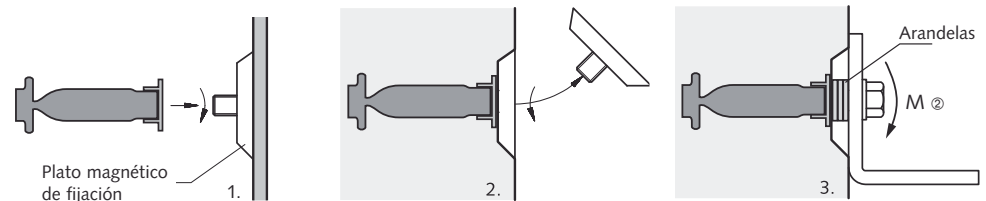

Retirar el encofrado,
desenroscar el plato magnético

① Par de Apriete T_{inst} → ver tabla pag. 25

② El Momento transmitido al tornillo debe ser verificado por el cliente (tornillos no incluidos)

Par de apriete T_{inst} [Nm]*

Métrica	T-FIXX®	Perno anclaje / Barra anclaje	Casquillo de anclaje
M10	≤ 8	-	≤ 4
M12	≤ 10	≤ 10	≤ 8
M16	≤ 30	≤ 30	≤ 17
M20	≤ 60	≤ 50	≤ 25
M24	-	≤ 90	≤ 53
M30	-	≤ 180	≤ 96
M36	-	≤ 250	-
M42	-	≤ 300	-

* Los pares de apriete se aplican solo a los pernos que no tienen lubricación.

Determinar la longitud del tornillo

General

La pieza de instalación se sujeta con un tornillo de métrica estándar y arandela o con una varilla. Los componentes de sujeción mencionados no están incluidos en el HALFEN DEMU, deben pedirse por separado. Los tornillos utilizados deben estar acorde con lo indicado por el ingeniero responsable.

Longitud de rosca del tornillo

Para todos los casquillos de fijación hay un máximo y un mínimo de longitud de rosca. Tenga en cuenta las longitudes de los tornillos. Las longitudes mínimas de roscado se resumen en la siguiente tabla. Los valores máximos correspondientes se pueden encontrar en las tablas en la siguiente página. Para encontrar la longitud de perno requerida, proceda como se describe a continuación.

Determinación de la longitud de perno requerida (L_s)Longitud de tornillo (L_s)

$L_{s,min}$ = $s + k$ (longitud mínima de tornillo)

$L_{s,max}$ = $a + k$ (longitud máxima de tornillo)

- k = espesor a fijar (espesor del angular metálico y espesor de las arandelas de fijación)
 s = longitud mínima roscada (→ ver tabla de abajo)
 a = longitud máxima roscada (→ ver tabla en página 25)

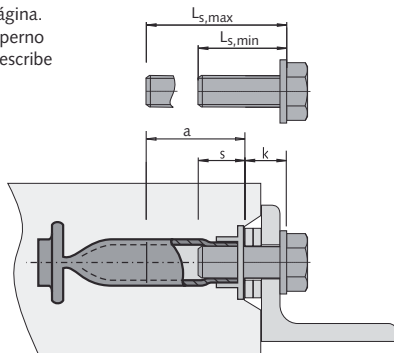
Longitud mínima roscada s [mm]

Métrica	T-FIXX®	Anclaje HALFEN DEMU 1988	Anclaje HALFEN DEMU 1985/1980-P / Barra de anclaje / Casquillo de anclaje ①,②
M6	-	-	7,2
M8	-	-	9,6
M10	17,0	-	12,0 / 15,0
M12	20,0	16,4	14,4 / 18,0
M16	26,0	21,2	19,2 / 24,0
M20	32,0	26,0	24,0 / 30,0
M24	-	30,8	28,8 / 36,0
M30	-	38,0	36,0
M36	-	45,2	43,2
M42	-	52,4	50,4

① valor $s = 1,2 \times d_{nom}$

② valores más altos ($s = 1,5 \times d_{nom}$) se aplican para fijar anclajes con placa de clavado integrada → tipos 1985 (GV), 1036-G (GV, A4) y 1130 (GV).

Longitud Máxima de rosca a [mm] para T-FIXX® ①		
Métrica / tipo de casquillo	a [mm]	
M10	all types	32,0
M12	M 12 × 50	30,0
	M 12 × 70	28,0
	M 12 × 95	
	M 12 × 115	
M16	M 16 × 60	32,0
	M 16 × 80	50,0
	M 16 × 100	
	M 16 × 110	
	M 16 × 125	
M 16 × 145		
M20	M 20 × 70	44,0
	M 20 × 100	62,0
	M 20 × 125	
	M 20 × 145	

① para el tipo T-FIXX® (GV, A4)

Longitud máxima de rosca a [mm] para casquillo de fijación / barras de fijación ②, ③	
Métrica	a [mm]
M12	23,0
M16	29,0
M20	35,0
M24	46,0
M30	60,0
M36	74,0
M42	68,0

② para los siguientes tipos:

- 1985 (GV)
- 1980-P (GV, FV, A4-80)
- 3016 (GV)
- 3010 (A4-80)
- 1980-S (GV)
- 1988-S (GV)
- 1554 (GV, FV, A4-80)
- 1558 (GV, FV, A4-80)

Métrica	4010/4030	1988*
	a [mm]	a [mm]
M12	-	25,0
M16	25,0	31,0
M20	33,0	37,0
M24	38,0	48,0
M30	48,0	62,0
M36	-	76,0
M42	65,0	70,0

③ para los siguientes tipos:

- 1988 (GV, FV, A4-50, A4-80)
- 4010 (GV, FV)
- 4030 (GV, FV)

* para anclajes de pernos con sellado especial en la parte inferior del manguito (tipos A4-50, A4-80), los valores deben reducirse en 3,0 mm.

Longitud máxima de rosca a [mm] para los casquillos de fijación ④-⑧		
Métrica / tipo de casquillo	a [mm]	
M6	M 6 × 30	14,0
	M 6 × 40	20,0
M8	M 8 × 40	18,0
	M 8 × 50	25,0

④ para el tipo 995-GB (GV)

Métrica / tipo de casquillo	a [mm]
M6	M 6 × 40

⑤ para el tipo 995 (A4)

Métrica / tipo de casquillo	a [mm]	
M8	M 8 × 50	20,0
M10	M 10 × 50	
M12	M 12 × 60 (GV)	23,0
	M 12 × 60 (A4)	25,0
	M 12 × 70	30,0
M16	M 16 × 70	25,0
	M 16 × 80	
	M 16 × 100 (A4)	
	M 16 × 100 (GV)	
	M 16 × 120	
M20	M 20 × 100	40,0
	M 20 × 120	70,0
M24	M 24 × 120	
M30	M 30 × 150	

⑥ para los siguientes tipos:

- 995-G (GV, A4)
- 1036-G (GV, A4)

Métrica / tipo de casquillo	a [mm]	
M8	M 8 × 50	30,0
M10	M 10 × 60	35,0
	M 10 × 70	40,0
M12	M 12 × 45	18,0
	M 12 × 70	40,0
M16	M 16 × 60	24,0
	M 16 × 100	32,0
M20	M 20 × 70	30,0
	M 20 × 100	40,0
M24	M 24 × 80	24,0

⑦ para los siguientes tipos:

- 1130 (GV)
- 1140 (GV, A4)

Métrica / tipo de casquillo	a [mm]	
M12	M 12 × 60	22,0
	M 16 × 75	22,0
M16	M 16 × 100	35,0
	M 20 × 90	25,0
M20	M 20 × 120	45,0
	M 24 × 100	30,0
M30	M 30 × 135	35,0

⑧ para el tipo 995-DG (GV)

Anker types

Deze montagehandleiding geldt voor de volgende DEMU bevestigingsankers:

T-FIXX®
 (GV, A4)

Stekanker, staafanker

types 4010 (GV, FV), 4030 (GV, FV), 3016 (GV),
 3010 (A4-80), 1980-S (GV), 1988-S (GV),
 1554 (GV, FV, A4-80), 1558 (GV, FV, A4-80)

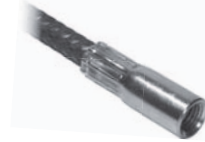
Boutanker

types 1988 (GV, FV, A4-50, A4-80), 1985 (GV),
 1980-P (GV, FV, A4-80)

Betonschroefhuls

types 995-GB (GV), 995 (A4), 995-G (GV, A4),
 995-DG (GV), 1036-G (GV, A4), 1130 (GV), 1140 (GV, A4)



Algemene inbouw-instructies

Zorg ervoor dat het oppervlak van het anker vrij is van vuil, olie, etc. om de optimale binding tussen bevestigingsanker en beton te garanderen.

Het beton moet zorgvuldig worden gestort; vermijd direct contact tussen verdichtingsapparatuur en bevestigingsanker. Extra vastzetten van de ankers aan de wapening wordt aanbevolen.

Bevestigingsankers kunnen gelijk met het oppervlak of verdiept worden ingebouwd. Bij verdiept ingebouwde ankers moeten sluitringen worden gebruikt ter ondersteuning.

Direct na het ontkisten dienen de spijkerplaten te worden verwijderd. **De binnenzijde van de draadbus dient na het ontkisten verder te worden beschermd tegen indringen**

van water, vuil of olie tot het moment van bevestigen.

Ook na de montage dient de binnenzijde van de draadbus te worden beschermd tegen indringen van water.

De bevestigingsbout moet worden gekozen op basis van de statische specificaties van de constructeur.

Minimale/maximale indraailengte(s) voor bevestigingsbouten en maximale aandraaimoment (T_{inst}) zijn te vinden in de tabellen op pag. 30 - 31.

Het bevestigingsanker mag niet op zijn volledige capaciteit worden belast voordat het beton de vereiste sterkte bereikt heeft.

Lassen

Alle stalen producten in de technische documentatie (HALFEN DEMU FIX) zijn lasbaar. Echter kan lassen, ook hechtlassen, de mechanische eigenschappen van de HALFEN DEMU-producten negatief beïnvloeden.

Indien lassen in de toepassing onvermijdelijk is, dient rekening te worden gehouden met het volgende:

- een mogelijke reductie van belastbaarheid en wijziging van gebruikseigenschappen.
- verwijder de eventueel aanwezige coatinglaag voor het lassen en zorg ervoor dat lasdampen veilig worden afgevoerd.
- gebruik voorgeschreven beschermingsmiddelen.
- de klant is verantwoordelijk voor naleving van de geldende lasvoorschriften.

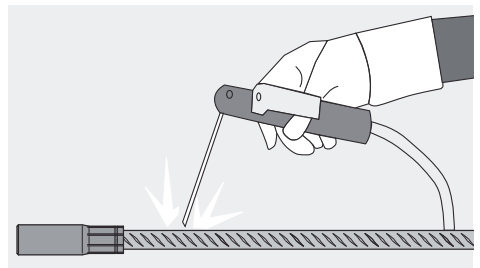

Leviat is niet aansprakelijk voor eventuele schade ontstaan aan of door HALFEN DEMU-producten waaraan gelast is.

Montage van accessoires

Flensplaat

type 2275 (h=2 mm)



type 2280 (h=10 mm)



Breekpen

type 2250



Afsluitdop

type 2244



Montagenippel

type 2600



Beschikbare diameter schroefdraad: M8 – M30

d_{nom}	M8*	M10	M12	M16	M20	M24	M30*
-----------	-----	-----	-----	-----	-----	-----	------

* alleen type 2280 beschikbaar

Afbeelding 1

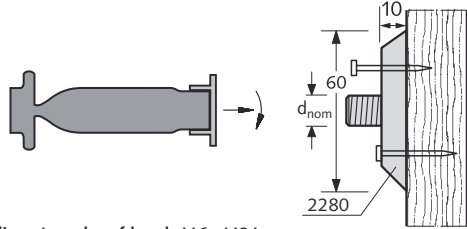

Beschikbare diameter schroefdraad: M6 – M24

d_{nom}	M6	M8	M10	M12	M16	M20	M24
\varnothing boorgat [mm]	11	11	11	11	17	17	17

Afbeelding 2

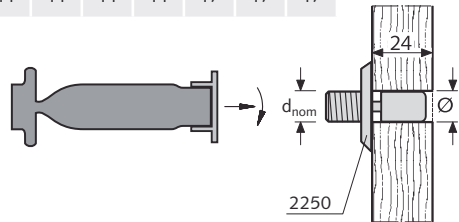

Beschikbare diameter schroefdraad: M6 – M42

d_{nom}	M6	M8	M10	M12	M16	M20	M24	M30	M36	M42
-----------	----	----	-----	-----	-----	-----	-----	-----	-----	-----

Afbeelding 3

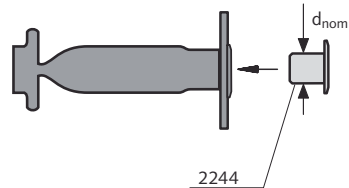

Beschikbare diameter schroefdraad: M12 – M42

d_{nom}	M12	M16	M20	M24	M30	M36	M42
d_B bevestigingsbout	M6	M8	M8	M10	M10	M10	M12

Afbeelding 4

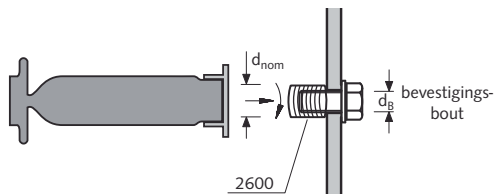

Montage in stappen (T-FIXX afgebeeld; bevestiging van de andere bevestigingsankers analoog)

Bevestiging aan de bekisting

Vorbereiding voor montage

Montage van de bout ①

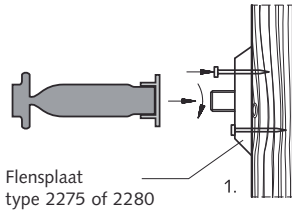
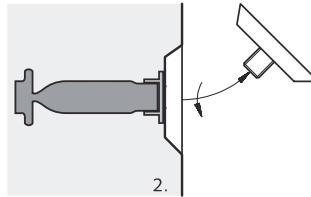
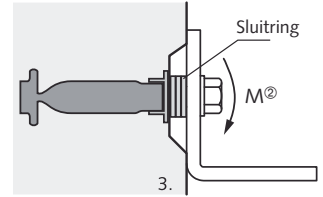
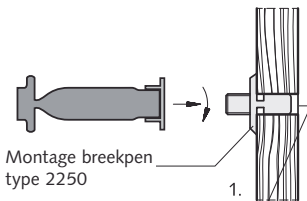
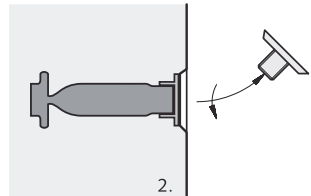
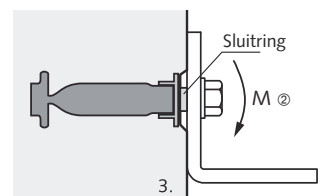
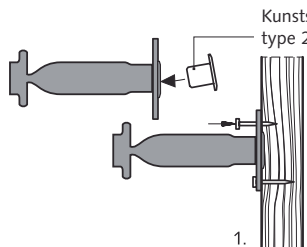
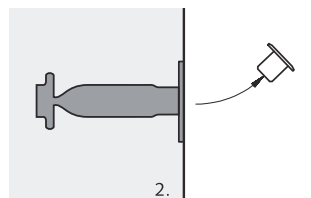
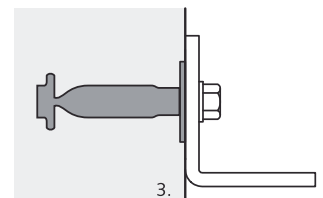
Voorbeeld A
met kunststof flensplaatFlensplaat
type 2275 of 2280Montage van flensplaat:
zie pag. 27, afbeelding 1Bekisting verwijderen,
flensplaat losdraaienVoorbeeld B
met kunststof breeкpenMontage breeкpen
type 2250Boorgat in bekisting:
zie pag. 27, afbeelding 2Bekisting verwijderen,
restant van breeкpen losdraaienVoorbeeld C
Bevestigingsanker met flensplaatBevestiging van afsluitdop:
zie pag. 27, afbeelding 3Bekisting verwijderen,
afsluitdop verwijderen① Moment T_{inst} → zie tabel op pag. 30

② Buiging van de bout moet door de klant worden gecontroleerd (bout is niet bij de levering inbegrepen)

Montage in stappen (T-FIXX afgebeeld; bevestiging van de andere bevestigingsankers analoog)

Bevestiging aan de bekisting

Vorbereiding voor montage

Montage van de bout ①

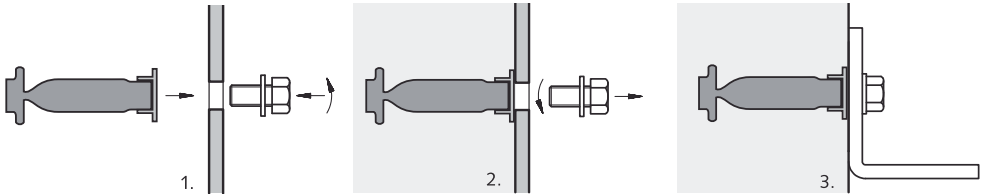
Voorbeeld D
met zeskantbout

Zeskantbout losdraaien,
bekisting verwijderen

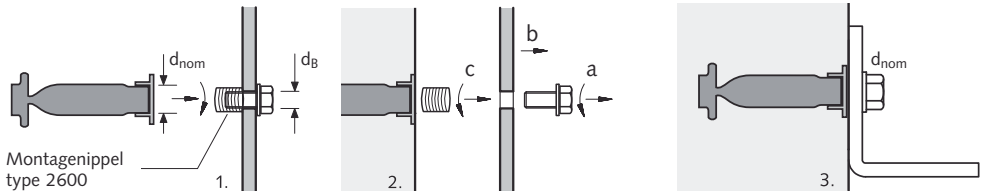
Voorbeeld E
met montagenippel en zeskantbout

Montagenippel
type 2600

Montage van montagenippel:
zie pag. 27, afbeelding 4

a) Zeskantbout losdraaien,
b) bekisting verwijderen,
c) montagenippel losdraaien

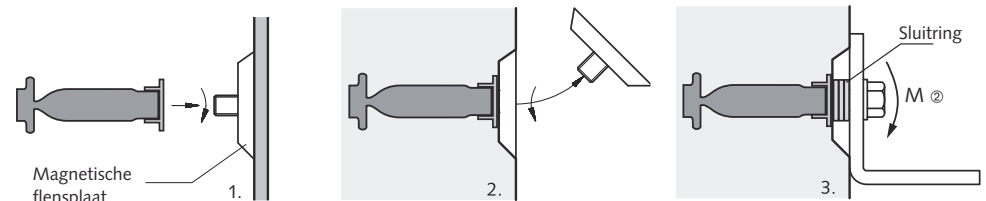
Voorbeeld F
met magnetische flensplaat aan
stalen bekisting

Magnetische
flensplaat

Bekisting verwijderen,
magnetische flensplaat losdraaien

① Moment T_{inst} → zie tabel op pag. 30

② Buiging van de bout moet door de klant worden gecontroleerd (bout is niet bij de levering inbegrepen)

Aandraaimoment T_{inst} [Nm]*			
Draaddiameter	T-FIXX®	Boutanker / Stekanker	Schroefhuls
M10	≤ 8	-	≤ 4
M12	≤ 10	≤ 10	≤ 8
M16	≤ 30	≤ 30	≤ 17
M20	≤ 60	≤ 50	≤ 25
M24	-	≤ 90	≤ 53
M30	-	≤ 180	≤ 96
M36	-	≤ 250	-
M42	-	≤ 300	-

* De aandraaimomenten gelden alleen voor bouten die niet voorzien zijn van vet.

Het bepalen van de boutlengte

Algemene informatie

De te bevestigen constructie is aan het ingebouwde anker bevestigd met een bevestigingsbout met standaard metrische draad en sluitring of met een draadstang, sluitring en moer. De bevestigingsonderdelen zijn niet bij de HALFEN DEMU bevestigingsystemen inbegrepen en dienen separaat te worden besteld. Het bevestigingsmiddel (bout) moet worden gekozen op basis van de statische specificaties van de constructeur.

Indraailengte van de bout

Voor alle bevestigingsmiddelen geldt een minimale en een maximale indraailengte. De minimale waarden zijn te vinden in onderstaande tabel. De bijbehorende maximale waarden voor elk type zijn te vinden in de tabellen op de volgende pagina. Voor het bepalen van de gewenste boutlengte zie toelichting hieronder.

Het bepalen van de vereiste boutlengte (L_s)

Boutlengte (L_s)
 $L_{s,min}$ = $s + k$ (minimale boutlengte)
 $L_{s,max}$ = $a + k$ (maximale boutlengte)

- k = klemdikte
 (dikte van de hoekstaal en de sluitringen)
 s = minimale indraailengte (→ zie tabel onder)
 a = maximale indraailengte (→ zie tabellen op pag. 31)

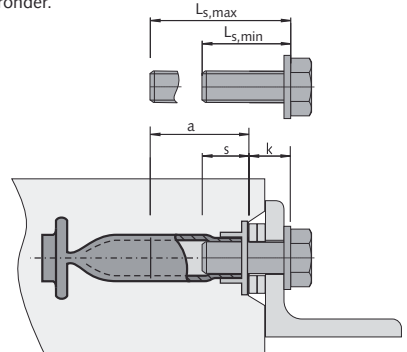

Minimale indraailengte s [mm]

Draaddiameter	T-FIXX®	Boutanker 1988	Boutanker 1985/1980-P / Stekanker / Schroefhuls ①,②
M6	-	-	7,2
M8	-	-	9,6
M10	17,0	-	12,0 / 15,0
M12	20,0	16,4	14,4 / 18,0
M16	26,0	21,2	19,2 / 24,0
M20	32,0	26,0	24,0 / 30,0
M24	-	30,8	28,8 / 36,0
M30	-	38,0	36,0
M36	-	45,2	43,2
M42	-	52,4	50,4

① $s = 1,2 \times d_{nom}$

② voor de bevestigingsankers met flensplaat gelden hogere waarden ($s = 1,5 \times d_{nom}$)
 → bevestigingsankers types 1985 (GV), 1036-G (GV, A4) en 1130 (GV).

Maximale indraailengte a [mm] voor T-FIXX® ①		
Draad diameter / Ankerafmeting		a [mm]
M10	afmetingen	32,0
	M 12 × 50	30,0
M12	M 12 × 70	28,0
	M 12 × 95	
	M 12 × 115	
M16	M 16 × 60	32,0
	M 16 × 80	50,0
	M 16 × 100	
	M 16 × 110	
	M 16 × 125	
M 20 × 70	44,0	
M20	M 20 × 100	62,0
	M 20 × 125	
	M 20 × 145	

① voor type T-FIXX® (GV, A4)

Maximale indraailengte a [mm] voor boutanker / stekanker ②,③	
Draad diameter	a [mm]
M12	23,0
M16	29,0
M20	35,0
M24	46,0
M30	60,0
M36	74,0
M42	68,0

② voor de volgende types:

1985 (GV)
1980-P (GV, FV, A4-80)
3016 (GV)
3010 (A4-80)
1980-S (GV)
1988-S (GV)
1554 (GV, FV, A4-80)
1558 (GV, FV, A4-80)

Draad diameter	4010/4030	1988*
	a [mm]	a [mm]
M12	-	25,0
M16	25,0	31,0
M20	33,0	37,0
M24	38,0	48,0
M30	48,0	62,0
M36	-	76,0
M42	65,0	70,0

③ voor de volgende types:

1988 (GV, FV, A4-50, A4-80)
4010 (GV, FV)
4030 (GV, FV)

* Voor boutankers met speciale afdichting aan de onderkant van de mof moeten de waarden met 3,0 mm worden verminderd (types A4-50, A4-80).

Maximale indraailengte a [mm] voor schroefhuuls ④-⑧		
Draad diameter / Ankerafmeting		a [mm]
M6	M 6 × 30	14,0
	M 6 × 40	20,0
M8	M 8 × 40	18,0
	M 8 × 50	25,0

④ voor type 995-GB (GV)

Draad diameter / Ankerafmeting		a [mm]
M6	M 6 × 40	25,0

⑤ voor type 995 (A4)

Draad diameter / Ankerafmeting		a [mm]
M8	M 8 × 50	20,0
M10	M 10 × 50	
M12	M 12 × 60 (GV)	23,0
	M 12 × 60 (A4)	25,0
	M 12 × 70	30,0
M16	M 16 × 70	25,0
	M 16 × 80	
	M 16 × 100 (A4)	
	M 16 × 100 (GV)	
	M 16 × 120	
M20	M 20 × 100	40,0
	M 20 × 120	
M24	M 24 × 120	50,0
M30	M 30 × 150	70,0

⑥ voor de volgende types:

995-G (GV, A4)
1036-G (GV, A4)

Draad diameter / Ankerafmeting		a [mm]
M8	M 8 × 50	30,0
M10	M 10 × 60	35,0
M12	M 12 × 45	18,0
	M 12 × 70	40,0
M16	M 16 × 60	24,0
	M 16 × 100	32,0
M20	M 20 × 70	30,0
	M 20 × 100	40,0
M24	M 24 × 80	24,0

⑦ voor de volgende types:

1130 (GV)
1140 (GV, A4)

Draad diameter / Ankerafmeting		a [mm]
M12	M 12 × 60	22,0
	M 16 × 75	22,0
M16	M 16 × 100	35,0
	M 20 × 90	25,0
M20	M 20 × 120	45,0
	M 24 × 100	30,0
M30	M 30 × 135	35,0

⑧ voor type 995-DG (GV)

Typy kotew

Instrukcja montażu obowiązuje dla następujących typów kotew tulejowych:

T-FIXX® (GV, A4)



Kotwy trzpieniowe

Typy 1988 (GV, FV, A4-50, A4-80), 1985 (GV), 1980-P (GV, FV, A4-80)



Kotwy prętowe

Typy 4010 (GV, FV), 4030 (GV, FV), 3016 (GV), 3010 (A4-80), 1980-S (GV), 1988-S (GV), 1554 (GV, FV, A4-80), 1558 (GV, FV, A4-80)

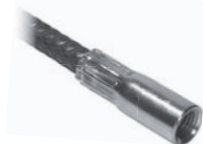

Kotwy tulejowe

Typy 995-GB (GV), 995 (A4), 995-G (GV, A4), 995-DG (GV), 1036-G (GV, A4), 1130 (GV), 1140 (GV, A4)



Ogólne wskazówki montażu

Aby zagwarantować dobre połączenie pomiędzy kotwą tulejową a betonem, należy zadbać, żeby kotwa nie była zabrudzona np. olejem. Mieszkankę betonową należy starannie rozłożyć unikając bezpośredniego kontaktu buławy wiratora z kotwą. Zalecane jest dodatkowe przywiązanie kotew do zbrojenia.

Kotwy tulejowe umieszczane są w licu powierzchni betonu lub zagłębione. W przypadku kotew zagłębionych, przy montażu elementu mocowanego stosuje się podkładki. Bezpośrednio po rozszalowaniu należy wykręcić talerzyki.

Wnętrze tulei gwintowanej, do czasu zamocowania elementu, należy chronić przed wnikaniem wody, zabrudzeń, oleju. Także po montażu końcowym należy zapewnić, aby do tulei nie wnikała woda.

Do zamocowania elementu budowlanego należy stosować przewidziane przez projektanta śruby.

Minimalne i maksymalne głębokości wkręcenia śrub mocujących w tuleje, jak również maksymalne momenty wkręcenia (T_{inst}) podane są w tabelach na stronach 36 - 37.

Obciążenie kotew tulejowych może nastąpić dopiero po osiągnięciu przez beton przewidzianej wytrzymałości.

Spawalność

Wszystkie stalowe produkty „DEMU FIX” umieszczone w katalogu są spawalne. Jednak każdy rodzaj spawania może negatywnie wpływać na właściwości mechaniczne produktów HALFEN DEMU.

Jeśli w szczególnych przypadkach zastosowań spawania nie da się uniknąć, należy zwracać uwagę na:

- możliwość wystąpienia ograniczonej funkcjonalności i nośności.
- ewentualne powłoki usunąć przed spawaniem
- należy stosować sprzęt ochronny.
- klient jest odpowiedzialny za dotrzymanie obowiązujących przepisów w zakresie procesu spawalniczego.

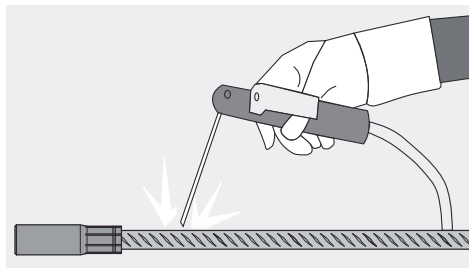

Leviat nie ponosi odpowiedzialności za szkodę wynikającą z zastosowania produktów, które zostały zespane.

Montaż osprzętu

Podkładka przytrzymała
typ 2275 (h = 2 mm)



typ 2280 (h = 10 mm)



Dybel montażowy
typ 2250



Zatyczka
typ 2244



Adapter gwintu
typ 2600



Dostępne rozmiary gwintów: M8 – M30

d_{nom}	M8*	M10	M12	M16	M20	M24	M30*
-----------	-----	-----	-----	-----	-----	-----	------

* Dostępny tylko typ 2280

Rysunek 1

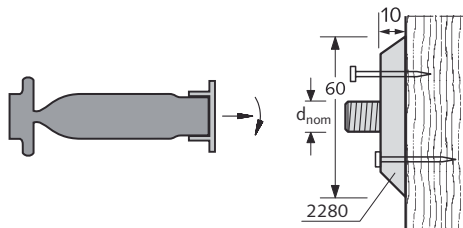

Dostępne rozmiary gwintów: M6 – M24

d_{nom}	M6	M8	M10	M12	M16	M20	M24
\varnothing otworu wierconego [mm]	11	11	11	11	17	17	17

Rysunek 2

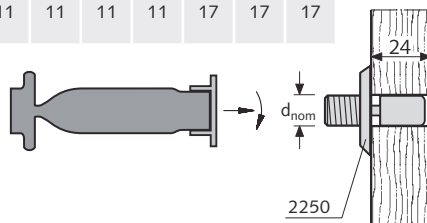

Dostępne rozmiary gwintów: M6 – M42

d_{nom}	M6	M8	M10	M12	M16	M20	M24	M30	M36	M42
-----------	----	----	-----	-----	-----	-----	-----	-----	-----	-----

Rysunek 3

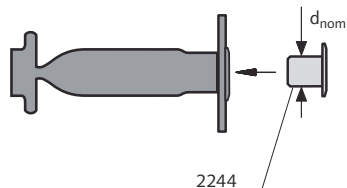

Dostępne rozmiary gwintów: M12 – M42

d_{nom}	M12	M16	M20	M24	M30	M36	M42
d_B śruby	M6	M8	M8	M10	M10	M10	M12

Rysunek 4

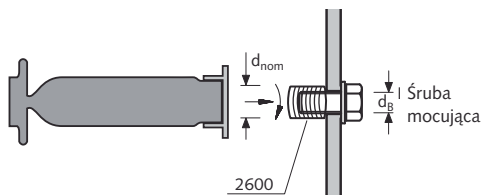

Montaż (ilustracja: T-FIXX; mocowanie innych typów tulei analogicznie)

Mocowanie do szalunku

Przygotowanie do montażu

Śrubę wkręcić i dociągnąć①

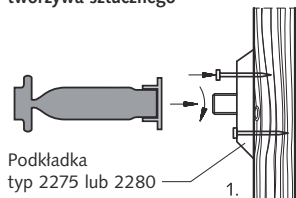
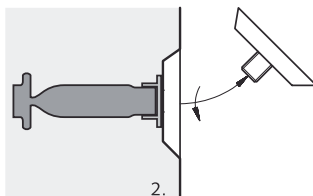
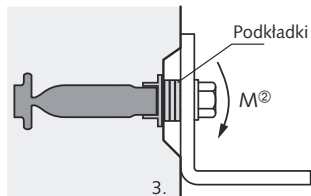
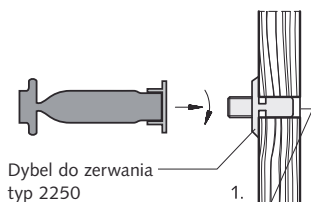
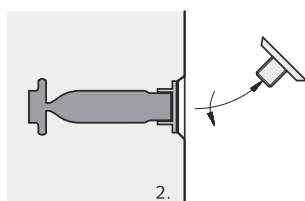
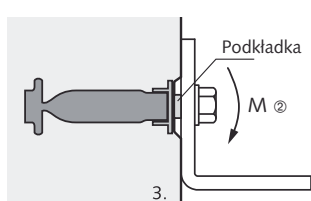
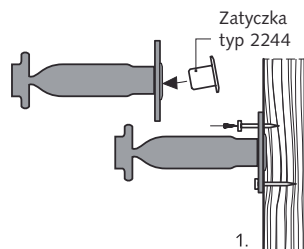
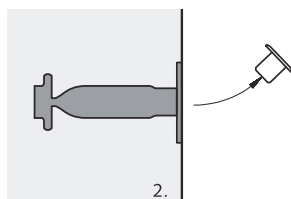
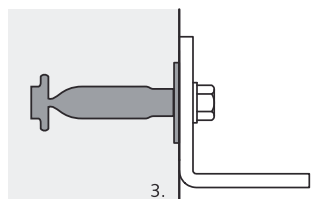
Przypadek A
podkładka przytrzymująca z
tworzywa sztucznegoPodkładka
typ 2275 lub 2280Usunąć szalunek,
wykręcić podkładkęPrzybić podkładkę:
patrz str. 33, rys. 1Przypadek B
montaż przy użyciu dybla do zerwaniaDybel do zerwania
typ 2250Usunąć szalunek,
wykręcić część gwintowanąOtwór w szalunku:
patrz str. 33, rys. 2Przypadek C
kotwy tulejowe ze zintegrowanym kołnierzemZatyczka
typ 2244Usunąć szalunek,
usunąć zatyczkęOsadzić zatyczkę w tulei:
patrz str. 33, rys. 3① moment dokręcenia T_{inst} → patrz tabela na str. 36

② należy uwzględnić zginanie śruby na skutek cofniętego położenia kotwy tulejowej (śruby nie są objęte dostawą)

Montaż (ilustracja: T-FIXX; mocowanie innych typów tulei analogicznie)

Mocowanie do szalunku

Przygotowanie do montażu

Śrubę wkręcić i dociągnąć ①

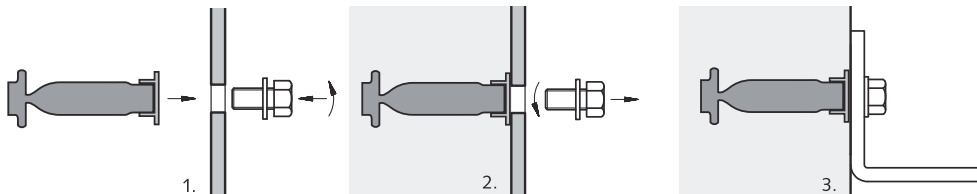
Przypadek D
ze śrubą sześciokątną

Wykręcić śrubę, usunąć szalunek,
usunąć szalunek

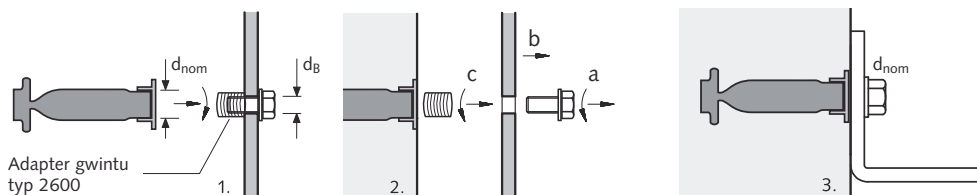
Przypadek E
z adapterem gwintu i śrubą sześciokątną

Adapter gwintu
typ 2600

Zamocować adapter:
patrz str. 33, rys. 4

a) Wykręcić śrubę sześciokątną,
b) usunąć szalunek,
c) wykręcić adapter gwintu

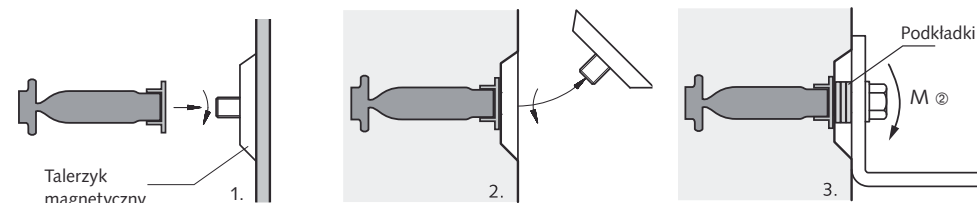
Przypadek F
talerzyk montażowy na szalunku
stalowym

Usunąć szalunek,
wykręcić talerzyk magnetyczny

① moment dokręcenia T_{inst} → patrz tabela na str. 36

② należy uwzględnić zginanie śruby na skutek cofniętego położenia kotwy tulejowej (śruby nie są objęte dostawą)

Moment wkręcenia T_{inst} [Nm]*

Rozmiar gwintu	T-FIXX®	Kotwa trzpieniowa/prętowa	Kotwa tulejowa
M10	≤ 8	-	≤ 4
M12	≤ 10	≤ 10	≤ 8
M16	≤ 30	≤ 30	≤ 17
M20	≤ 60	≤ 50	≤ 25
M24	-	≤ 90	≤ 53
M30	-	≤ 180	≤ 96
M36	-	≤ 250	-
M42	-	≤ 300	-

* Momenty obowiązują tylko dla śrub w stanie nie nasmarowanym.

Określenie wymaganej długości śrub

Ogólnie

Element budowlany mocowany jest przy pomocy śruby z gwintem metrycznym, podkładki i nakrętki konstruującej w zabetonowanej kotwie tulejowej. Wymienione komponenty do mocowania nie są zawarte w dostawie i muszą być oddzielnie zamawiane. Należy stosować śruby według wytycznych projektanta.

Długość wkręcenia

Przy stosowaniu kotew tulejowych należy zwracać uwagę na minimalne i maksymalne długości wkręcenia śrub. Minimalne długości wkręcenia zestawiono w tabeli poniżej. Określenie wymaganej długości śrub opisane jest w następnym punkcie.

Określenie wymaganej długości śruby (L_s)Długość śruby (L_s)

$L_{s,min}$ = $s + k$ (minimalna długość śruby)
 $L_{s,max}$ = $a + k$ (maksymalna długość śruby)

- k = grubość mocowania (grubość elementu budowlanego i podkładki)
 s = minimalna długość wkręcenia (→ patrz tabela poniżej)
 a = maksymalna długość wkręcenia (→ patrz tabele na str. 37)

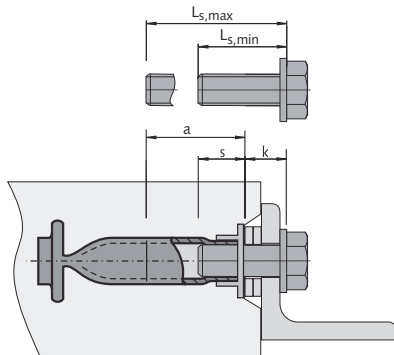
Minimalne długości wkręcenia s [mm]

Rozmiar gwintu	T-FIXX®	Kotwa trzpieniowa 1988	Kotwy trzpieniowe 1985/1980-P / kotwy prętowe / kotwy tulejowe ①,②
M6	-	-	7,2
M8	-	-	9,6
M10	17,0	-	12,0 / 15,0
M12	19,0	16,4	14,4 / 18,0
M16	26,0	21,2	19,2 / 24,0
M20	32,0	26,0	24,0 / 30,0
M24	-	30,8	28,8 / 36,0
M30	-	38,0	36,0
M36	-	45,2	43,2
M42	-	52,4	50,4

① $s = 1,2 \times d_{nom}$

② większe wartości ($s = 1,5 \times d_{nom}$) obowiązują dla kotew tulejowych ze zintegrowanym kołnierzem → typy 1985 (GV), 1036-G (GV, A4) i 1130 (GV).

Maksymalne długości wkręcenia a [mm] dla T-FIXX® ①		
Rozmiar gwintu / wielkość kotew		a [mm]
M10	wszystkie rozmiary	32,0
M12	M 12 × 50	30,0
	M 12 × 70	28,0
	M 12 × 95	
	M 12 × 115	
M16	M 16 × 60	32,0
	M 16 × 80	50,0
	M 16 × 100	
	M 16 × 110	
	M 16 × 125	
M 16 × 145		
M20	M 20 × 70	44,0
	M 20 × 100	62,0
	M 20 × 125	
	M 20 × 145	

① dla typu T-FIXX® (GV, A4)

Maksymalne długości wkręcenia a [mm] dla kotew trzpieniowych / kotew prętowych ②, ③	
Rozmiar gwintu	a [mm]
M12	23,0
M16	29,0
M20	35,0
M24	46,0
M30	60,0
M36	74,0
M42	68,0

② dla następujących typów:

1985 (GV)
1980-P (GV, FV, A4-80)
3016 (GV)
3010 (A4-80)
1980-S (GV)
1988-S (GV)
1554 (GV, FV, A4-80)
1558 (GV, FV, A4-80)

Rozmiar gwintu	4010/4030	1988*
	a [mm]	a [mm]
M12	-	25,0
M16	25,0	31,0
M20	33,0	37,0
M24	38,0	48,0
M30	48,0	62,0
M36	-	76,0
M42	65,0	70,0

③ dla następujących typów:

1988 (GV, FV, A4-50, A4-80)
4010 (GV, FV)
4030 (GV, FV)

* dla kotew trzpieniowych typu A4-50, A4-80, wartości należy zmniejszyć o 3mm.

Maksymalne długości wkręcenia a [mm] dla kotew tulejowych ④-⑥		
Rozmiar gwintu / wymiar kotwy		a [mm]
M6	M 6 × 30	14,0
	M 6 × 40	20,0
M8	M 8 × 40	18,0
	M 8 × 50	25,0

④ dla typu 995-GB(GV)

Rozmiar gwintu / wymiar kotwy		a [mm]
M6	M 6 × 40	25,0

⑤ dla typu 995(A4)

Rozmiar gwintu / wymiar kotwy		a [mm]
M8	M 8 × 50	20,0
M10	M 10 × 50	
M12	M 12 × 60 (GV)	23,0
	M 12 × 60 (A4)	25,0
	M 12 × 70	30,0
M16	M 16 × 70	25,0
	M 16 × 80	
	M 16 × 100 (A4)	32,0
	M 16 × 100 (GV)	
	M 16 × 120	
M20	M 20 × 100	40,0
	M 20 × 120	50,0
M24	M 24 × 120	
M30	M 30 × 150	

⑥ dla następujących typów:

995-G (GV, A4)
1036-G (GV, A4)

Rozmiar gwintu / wymiar kotwy		a [mm]
M8	M 8 × 50	30,0
M10	M 10 × 60	35,0
M12	M 12 × 45	18,0
	M 12 × 70	40,0
M16	M 16 × 60	24,0
	M 16 × 100	32,0
M20	M 20 × 70	30,0
	M 20 × 100	40,0
M24	M 24 × 80	24,0

⑦ dla następujących typów:

1130 (GV)
1140 (GV, A4)

Rozmiar gwintu / wymiar kotwy		a [mm]
M12	M 12 × 60	22,0
	M 16 × 75	22,0
M16	M 16 × 100	35,0
	M 20 × 90	25,0
M20	M 20 × 120	45,0
	M 24 × 100	30,0
M30	M 30 × 135	35,0

⑧ dla typu 995-DG (GV)

English

Deutsch

Français

Español

Nederlands

Polski

For more information on the products featured here, please contact Leviat:

Australia

Leviat
98 Kurrajong Avenue,
Mount Druitt, Sydney, NSW 2770
Tel: +61 - 2 8808 3100
Email: info.au@leviat.com

Austria

Leviat
Leonard-Bernstein-Str. 10
Saturn Tower, 1220 Wien
Tel: +43 - 1 - 259 6770
Email: info.at@leviat.com

Belgium

Leviat
Borkelstraat 131
2900 Schoten
Tel: +32 - 3 - 658 07 20
Email: info.be@leviat.com

China

Leviat
Room 601 Tower D,
Vantone Centre
No. A6 Chao Yang Men Wai Street
Chaoyang District
Beijing · P.R. China 100020
Tel: +86 - 10 5907 3200
Email: info.cn@leviat.com

Czech Republic

Leviat
Business Center Šafránková
Šafránková 1238/1
155 00 Praha 5
Tel: +420 - 311 - 690 060
Email: info.cz@leviat.com

Finland

Leviat
Vädursgatan 5
412 50 Göteborg / Sweden
Tel: +358 (0)10 6338781
Email: info.fi@leviat.com

France

Leviat
18, rue Goubet
75019 Paris
Tel: +33 - 1 - 44 52 31 00
Email: info.fr@leviat.com

Germany

Leviat
Liebigstrasse 14
40764 Langenfeld
Tel: +49 - 2173 - 970 - 0
Email: info.de@leviat.com

India

Leviat
309, 3rd Floor, Orion Business Park
Ghodbunder Road, Kapurbawdi,
Thane West, Thane,
Maharashtra 400607
Tel: +91 - 22 2589 2032
Email: info.in@leviat.com

Italy

Leviat
Via F.lli Bronzetti 28
24124 Bergamo
Tel: +39 - 035 - 0760711
Email: info.it@leviat.com

Malaysia

Leviat
28 Jalan Anggerik Mokara 31/59
Kota Kemuning,
40460 Shah Alam Selangor
Tel: +603 - 5122 4182
Email: info.my@leviat.com

Netherlands

Leviat
Oostermaat 3
7623 CS Borne
Tel: +31 - 74 - 267 14 49
Email: info.nl@leviat.com

New Zealand

Leviat
2/19 Nuttall Drive, Hillsborough,
Christchurch 8022
Tel: +64 - 3 376 5205
Email: info.nz@leviat.com

Norway

Leviat
Vestre Svanholmen 5
4313 Sandnes
Tel: +47 - 51 82 34 00
Email: info.no@leviat.com

Philippines

Leviat
2933 Regus, Joy Nostalgy,
ADB Avenue, Ortigas Center
Pasig City
Tel: +63 - 2 7957 6381
Email: info.ph@leviat.com

Poland

Leviat
Ul. Obornicka 287
60-691 Poznań
Tel: +48 - 61 - 622 14 14
Email: info.pl@leviat.com

Singapore

Leviat
14 Benoi Crescent
Singapore 629977
Tel: +65 - 6266 6802
Email: info.sg@leviat.com

Spain

Leviat
Polígono Industrial Santa Ana
c/ Ignacio Zuloaga, 20
28522 Rivas-Vaciamadrid
Tel: +34 - 91 632 18 40
Email: info.es@leviat.com

Sweden

Leviat
Vädursgatan 5
412 50 Göteborg
Tel: +46 - 31 - 98 58 00
Email: info.se@leviat.com

Switzerland

Leviat
Hertstrasse 25
8304 Wallisellen
Tel: +41 (0)800 22 66 00
Email: info.ch@leviat.com

United Arab Emirates

Leviat
RA08 TB02, PO Box 17225
JAFZA, Jebel Ali, Dubai
Tel: +971 (0)4 883 4346
Email: info.ae@leviat.com

United Kingdom

Leviat
A1/A2 Portland Close
Houghton Regis LU5 5AW
Tel: +44 - 1582 - 470 300
Email: info.uk@leviat.com

USA/Canada

Leviat
6467 S Falkenburg Road
Riverview, FL 33578
Tel: (800) 423-9140
Email: info.us@leviat.us

For countries not listed

Email: info@leviat.com

Leviat.com

Halfen.com

For information on certified management systems and standards, see www.halfen.com

Notes regarding this document

© Protected by copyright. The information in this publication is based on state-of-the-art technology at the time of publication. In every case, project working details should be entrusted to appropriately qualified and experienced persons. Leviat shall not accept liability for the accuracy of the information in this document or for any printing errors. We reserve the right to make technical and design changes at any time. With a policy of continuous product development, Leviat reserves the right to modify product design and specification at any time.

